



*Manufacturers of Process  
Controls and Instrumentation*

# ***Instruction Manual***

Model: *ITC-XX*

Function: *Isolator*

Input:  X=1: 1-5 mA       X=4: 10-50 mA  
 X=2: 4-20 mA       X=5: 1-5 VDC  
 X=3: 0-1 mA       X=6: 0-10 VDC  
    ■ X=7: \_\_\_\_\_

Output:  X=1: 1-5 mA       X=4: 10-50 mA  
 X=2: 4-20 mA       X=5: 1-5 VDC  
 X=3: 0-1 mA       X=6: 0-10 VDC  
    ■ X=7: \_\_\_\_\_

Power:   
    ■ 24 VDC, 160 mA Max  
 \_\_\_\_\_

Serial #: \_\_\_\_\_  
(If special or required)

For Technical Assistance And Questions Call  
USA: (231) 788-2900    CANADA: (905) 660-5336

## Restocking Policy

**All product returned to Pribusin Inc. in prime condition (not damaged, scratched or defaced in any way) within seven (7) months from the original date of shipment is subject to a 50% restocking charge. All product must be accompanied by a Return Authorization number (RA number) which must be obtained from Pribusin Inc. prior to returning any product.**

**After seven (7) months from the original date of shipment, products cannot be returned for restocking.**

**Custom designed products, modified products or all non-standard products may not be returned for restocking.**

## Warranty Policy

**Pribusin Inc. warrants equipment of its own manufacture to be free from defects in material and workmanship, under normal conditions of use and service, and will replace any component found to be defective, on its return to Pribusin Inc., transportation charges prepaid, within one year of its original purchase. Pribusin Inc. will extend the same warranty protection on equipment, peripherals and accessories which is extended to Pribusin Inc. by the original manufacturer. Pribusin Inc. also assumes noliability, expressed or implied, beyond its obligation to prelace any component involved. Such warranty is in lieu of all other warranties, expressed or implied.**

## Isolated Terminal Signal Conditioner



No cleaning must be provided

Din-rail mounting (width 22.5 mm.)

### Standard Features:

- High Input-Output-Power Isolation (2000 VAC Test for 1 second)
- Low Input Impedance on 4-20mA Inputs
- Small Size - Fits on Terminal Block Rail
- Industry Standard Inputs and Outputs (see back)
- High Output Drive (1000 Ohms for 4-20 mA)
- Two Wire Supply Option for Two Wire Transmitters
- Power: 24 VDC 80 - 160 mA
- High Noise Rejection
- CSA Certification 2054910



Pollution Degree 2

Installation Category II

Do Not Expose To Direct Sunlight

The ITC-XX is a signal isolator that provides high isolation from Input to Output to Power in a small, easy to install package. The universal DIN rail mount often makes it possible to install the ITC-XX right next to the instrument that is to be isolated. The many different input and output configurations allow it to be used in a great variety of applications ranging from PLC front end conditioning.

The high output drive (1000 Ohms @ 4-20 mA) allows the ITC-XX to drive several other instruments directly from its output. The standard two wire supply allows the ITC-XX to be used with two wire field transmitters such as differential pressure transducers and temperature sensors, etc.

If the equipment is used in a manner not specified by the manufacturer, the protection provided by the equipment may be impaired

### Specifications:

	ITC-XX	ITC-SLXX	ITC-MVXX	ITC-TXXX
Power <sup>1)</sup>	12VDC 24VDC 40VDC	170mA, 330mA max. 80mA, 160mA max. 55mA, 110mA max.	175mA max. 85mA max. 60mA max.	170mA max. 80mA max. 55mA max.
Isolation	High Input to Output to Power (2000 VAC Test for 1 second)			
Input Impedance	see Input table	10 Meg Ohm	10 Meg Ohm	10 Meg Ohm
Accuracy / Linearity	+/-0.2% max., +/- 0.1% typ.	+/-0.2% max., +/- 0.1% typ.	+/-0.3% max., Drift 1µV/°C	Linear with Material ± 2°C
Loop Res. D Effect	-0.1% per 100 Ohms change			
Common Mode Rej.	at 60 Hz = 120 dB			
Response Time	50 msec to 63%	75 msec to 63%	100 msec to 63%	100 msec to 63%
Drift at 25 Deg.C	24 Hours: ± 0.03%, 30 Days: ± 0.1%		24 Hours: ± 0.3%, 30 Days: ± 0.8%	
Operating Temp.	-40 Deg. C. to + 50 Deg. C.			
Environment	Altitude: 0-6562 ft (0-2000 m) Humidity: 0-95% RH non-condensing			

<sup>1)</sup> **CAUTION** To be powered by a class 2 source.

( Maximum Signal Input 30VAC or 60VDC or 5Amps) (Maximum Signal Output 30VDC or 50mA)

# ITC-XX-XX-DC

## Connection:

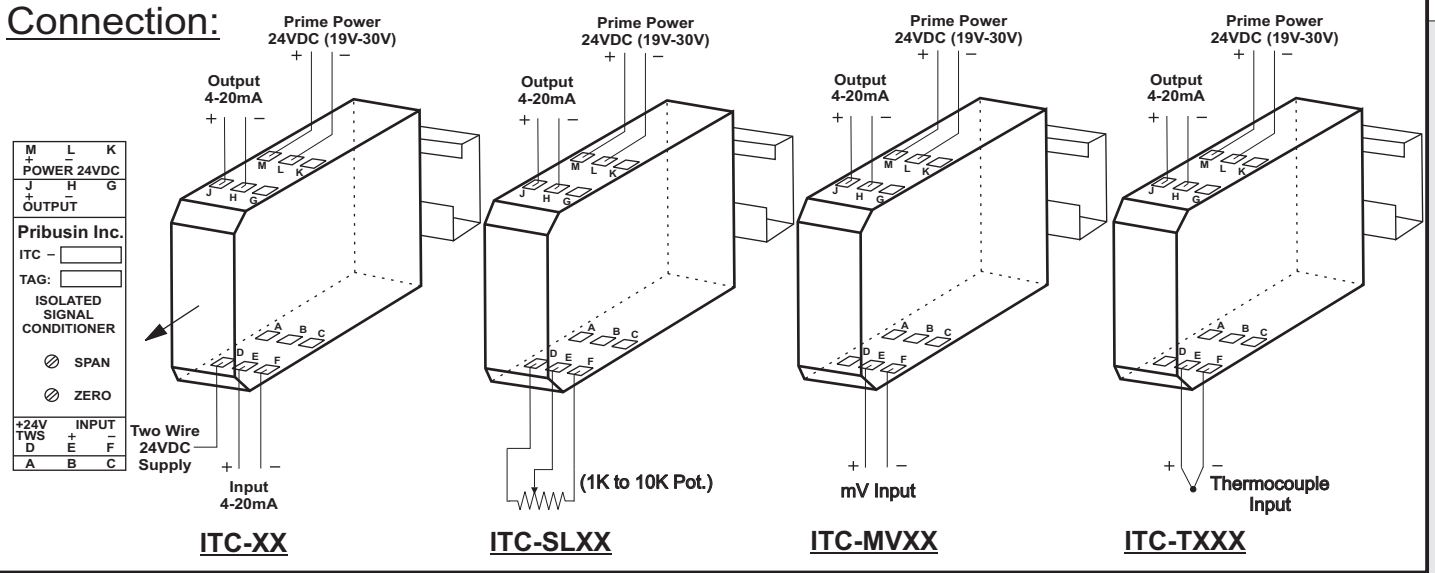

## Model Designation:

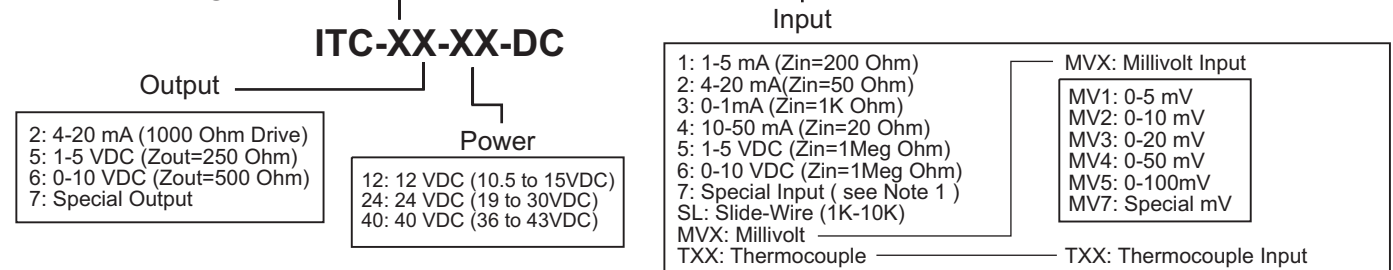

## Dimensions:

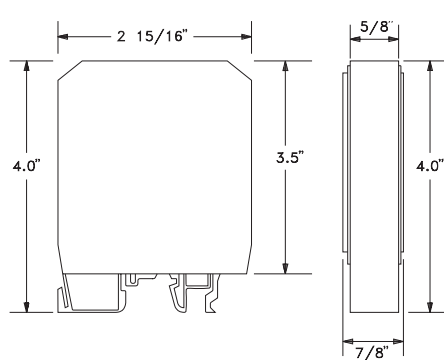

## Model Designation Examples:

1. Isolator with 4-20mA input, 4-20mA output, powered by 24VDC is: **ITC-22-24-DC**
2. Isolator with 0-50mV input, 0-10VDC outputs powered by 12VDC is: **ITC-MV46-12-DC**
3. Isolator with type 'K' thermocouple input for 0-750°F and 4-20mA output, powered by 24VDC is: **ITC-TK32-24-DC**

Range	Type	J	K	E	T	R	S
0 to 300F -18 to 150C		TJ1		TE1	TT1		
0 to 400F -18 to 204C		TJ2	TK1	TE2	TT2		
0 to 500F -18 to 260C		TJ3	TK2	TE3	TT3		
0 to 750F -18 to 400C		TJ4	TK3	TE4		TR1	TS1
0 to 1000F -18 to 538C		TJ5	TK4			TR2	TS2
0 to 1500F -18 to 816C			TK5			TR3	TS3
0 to 2000F -18 to 1093C			TK6			TR4	TS4
0 to 3200F -18 to 1760C						TR5	TS5
-350 to 1100F -200 to 600C		TJ6		TE5			

( Note 1. Maximum Signal Input 30VAC or 60VDC or 5Amps)

Manufactured By:

**Pribusin Inc.**

www.pribusin.com  
info@pribusin.com

### USA:

Pribusin Inc.  
743 Marquette Ave.  
Muskegon, MI 49442  
Ph: (231) 788-2900  
Fx: (231) 788-2929



### CANADA:

Pribusin Inc.  
101 Freshway Dr. Unit 57  
Concord, Ontario, L4K 1R9  
Ph: (905) 660-5336  
Fx: (905) 660-4068

# NORMAL CONNECTION

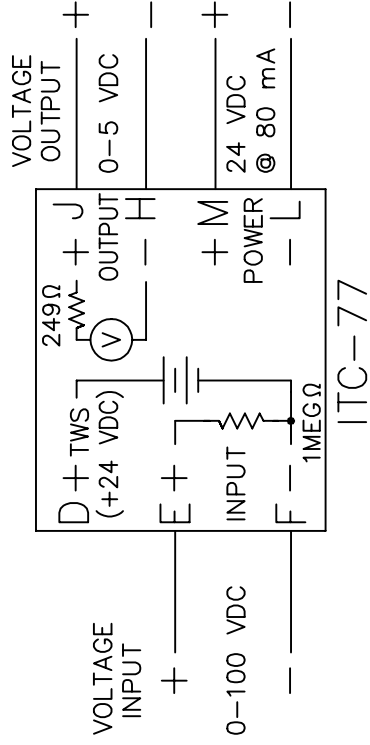

M	L	K
+	-	
POWER		
J	H	G
+	-	
OUTPUT		
Pribusin Inc.		
ITC - 77		
TAG: <input type="text"/>		
ISOLATED SIGNAL CONDITIONER		
⊕ SPAN		
⊕ ZERO		
+24V	INPUT	-
TWS	+	F
D	E	C
A	B	

Prime Power  
24 VDC (20-36 V)

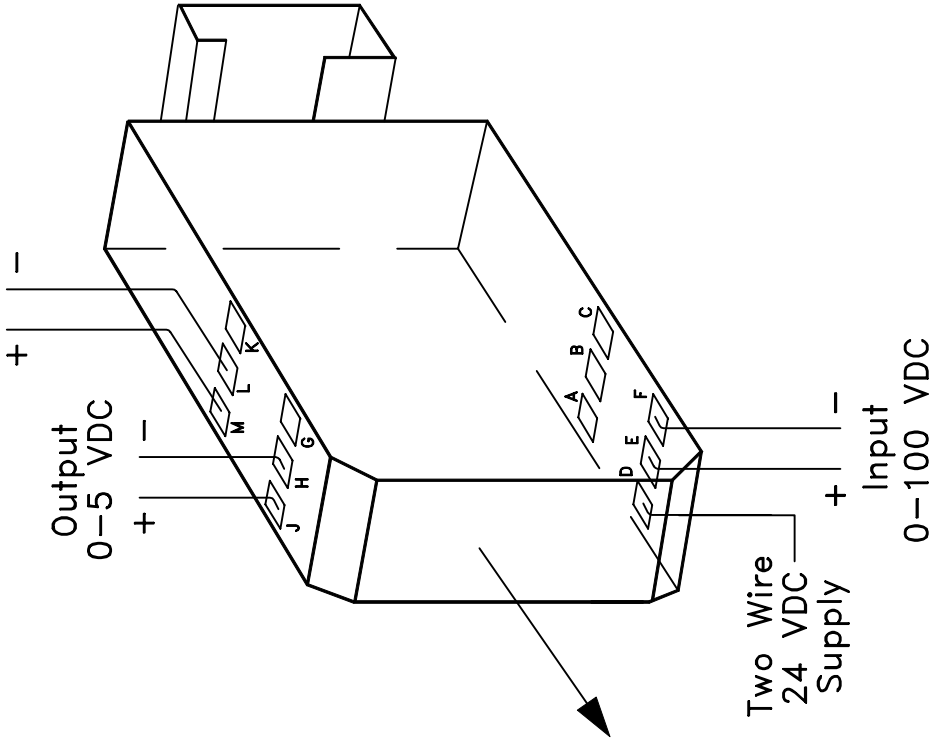

<b>Pribusin Inc. ©</b>		
CHKD :	DATE : NOV. 03/93	DRN: KS
Model: ITC-77 Isolated Terminal Signal Conditioner Connection Diagram		
DWG. NO. :	104587-S	REV. A

**Note:**  
For Detail of Terminal Block Enclosure/  
Din Rail See Dwg. 104384.

## Enclosure Detail :

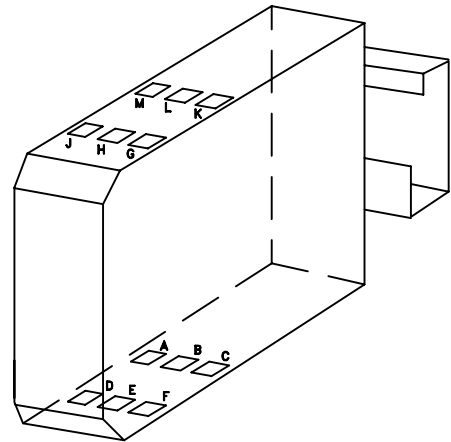
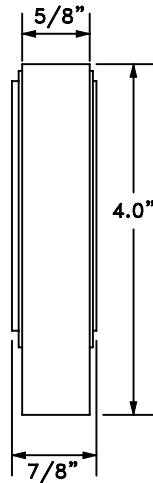
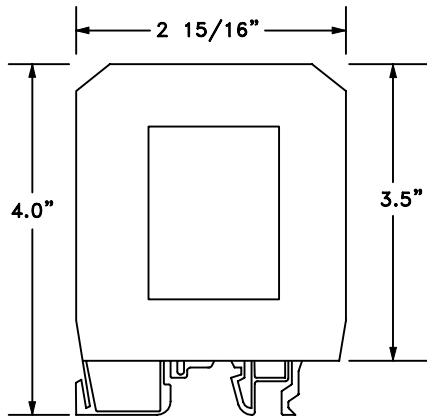

## Din Rail Detail :

	<p>A</p> <p>Rail Standard EN 50 035 Dimensions: 32 x 15 x 1.5 mm</p>
	<p>B</p> <p>Rail Standard DIN EN 50 022 Dimensions: 35 x 15 x 2.3 mm</p>
	<p>C</p> <p>Rail Standard DIN EN 50 022 Dimensions: 35 x 7.5 x 1 mm</p>
	<p>D</p> <p>Rail Standard DIN EN 50 022 Dimensions: 35 x 15 x 1.5 mm</p>

**Pribusin Inc. ©**

CHKD:

DATE: APR. 26/93

DRN: KS

Terminal Block Enclosure/  
Din Rail Detail

DWG. NO. :

104384

REV. A