

*Manufacturers of Process  
Controls and Instrumentation*

## ***Instruction Manual***

Model: *ITC-79-FTF*

Function: *Frequency to Frequency Isolator*

Option:  -DIV (Frequency Divider)  
 -BUF (Frequency/Pulse Buffer)

Input:  0-10 VDC  
 \_\_\_\_\_

Thresholds:  ON: TP1=3V    OFF: TP2=1V  
 ON: TP1= \_\_\_    OFF: TP2= \_\_\_

Response Time:  100 microsec.  
 \_\_\_\_\_

Relay:  Not Installed     Installed

Power:  24 VDC, 160 mA

Serial #: \_\_\_\_\_  
(If special or required)

For Technical Assistance And Questions Call  
USA: (734) 677-0459    CANADA: (905) 660-5336

## Restocking Policy

**All product returned to Pribusin Inc. in prime condition (not damaged, scratched or defaced in any way) within seven (7) months from the original date of shipment is subject to a 50% restocking charge. All product must be accompanied by a Return Authorization number (RA number) which must be obtained from Pribusin Inc. prior to returning any product.**

**After seven (7) months from the original date of shipment, products cannot be returned for restocking.**

**Custom designed products, modified products or all non-standard products may not be returned for restocking.**

## Warranty Policy

**Pribusin Inc. warrants equipment of its own manufacture to be free from defects in material and workmanship, under normal conditions of use and service, and will replace any component found to be defective, on its return to Pribusin Inc., transportation charges prepaid, within one year of its original purchase. Pribusin Inc. will extend the same warranty protection on equipment, peripherals and accessories which is extended to Pribusin Inc. by the original manufacturer. Pribusin Inc. also assumes noliability, expressed or implied, beyond its obligation to prelace any component involved. Such warranty is in lieu of all other warranties, expressed or implied.**



### Standard Features:

- DIN-Rail Mount (small size)
- High Input-Output-Power Isolation (800VAC Test)
- Wide Input Frequency Range (from 0 Hz to 10 KHz)
- Many Input Types & Ranges (Voltage, Dry Contact)
- 3 Standard Outputs (TTL, 24V, Dry Contact)
- Optional Buffer or Divider Function
- Adjustable Response Time for Noise Rejection
- Easy Field Calibration (Typ. calibration time < 2 min. using handheld meter only)
- Microprocessor Controlled for High Accuracy
- 24 VDC Supply for Dry Contact Input
- Power: 24 VDC
- CSA and NRTL Approval Pending

### Function:

The ITC-79-FTF is a Frequency to Frequency Isolator that is easily field configurable to one of many input types such as several voltages or dry contact. Three standard outputs are available (TTL, 24 VDC, and Dry Contact) which can be used individually or simultaneously. Discrete ON and OFF threshold adjustments allow for easy & accurate input signal conditioning. Adjustable response times allow for appropriate signal filtering.

The ITC-79-FTF-BUF is similar to the -FTF but has a microprocessor that can store incoming pulses in a buffer and release them slowly to a slower counting device.

The ITC-79-FTF-DIV is another variation of the -FTF and has the capability to divide the incoming frequency by any number between 1 and 65535.

### Calibration:

The ITC-79-FTF has individual ON and OFF threshold adjustment using multiturn potentiometers. All potentiometers have a test point where a voltage of -10 to +10 VDC indicates the threshold level as -100% to +100%. This allows for easy field calibration with the instrument running.

### Specifications:

- Isolation: Input to Output to Power 800 VAC (test)
- Operating Temperature: -40 Deg.C. to +50 Deg.C.
- Temperature Effects: +/-0.5% max., 0.2% typ.  
(for 40 Deg.C. change)
- Contact Rating: 0.4A @ 125VAC  
2A @ 30VDC

# ITC-79-FTF

## Dimensions:

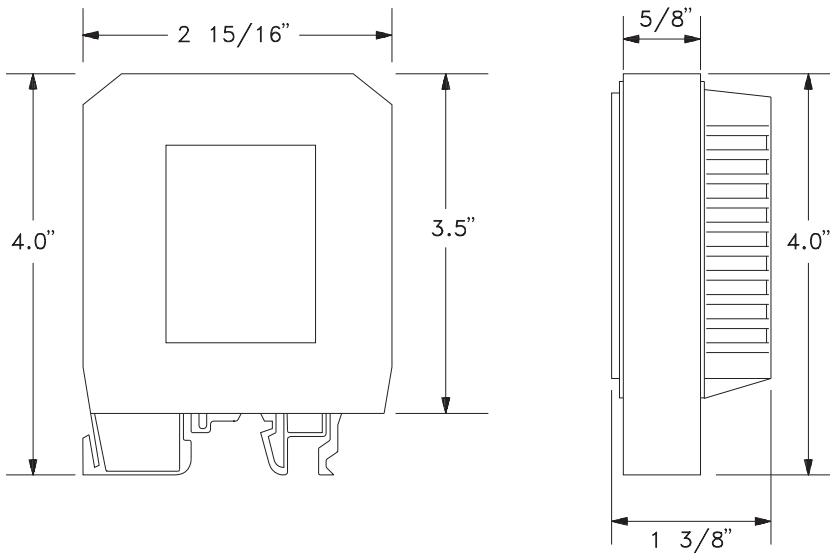

## Calibration:

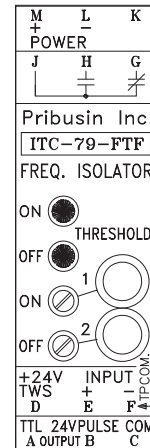

Calibration is made easy by multi turn potentiometers with test jacks for meter connection.

## Connection:

### ITC-79-FTF NORMAL CONNECTION

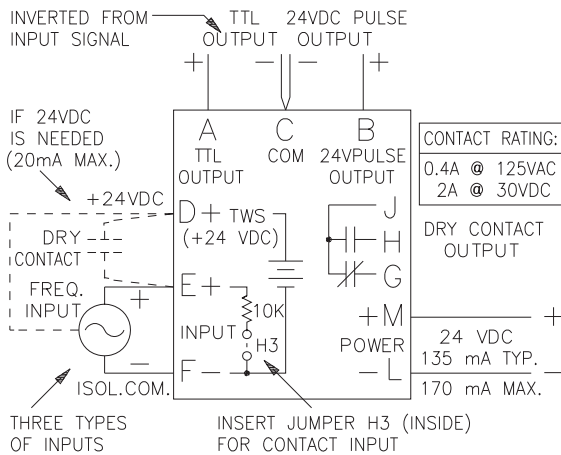

## Available Models:

**ITC-79-FTF: Frequency Isolator**  
Outputs: TTL, 24VDC, Dry Contact

**ITC-79-FTF-BUF: Frequency Isolator with Buffer**  
Outputs: TTL, 24VDC, Dry Contact  
Function: Store Pulses & Release Slowly

**ITC-79-FTF-DIV: Frequency Isolator with Divider**  
Outputs: TTL, 24VDC, Dry Contact  
Function: Divide Input by Division Factor

Manufactured By:

**Pribusin Inc.**

www.pribusin.com  
info@pribusin.com

**USA:**  
Pribusin Inc.  
743 Marquette Ave  
Muskegon, MI 49442  
Ph: (231) 788-2900  
Fx: (231) 788-2929



**CANADA:**  
Pribusin Inc.  
101 Freshway Dr. Unit 57  
Concord, Ontario, L4K 1R9  
Ph: (905) 660-5336  
Fx: (905) 660-4068

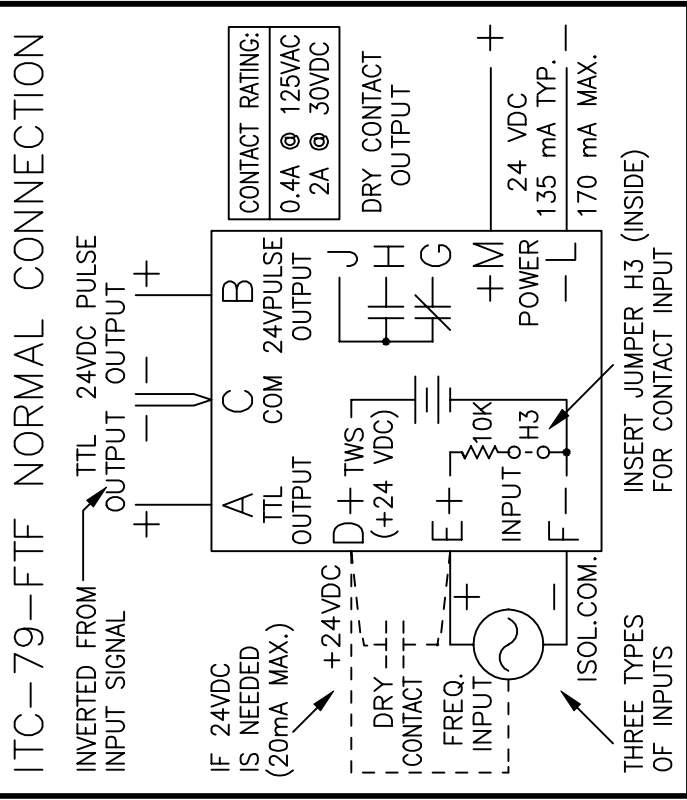

<b>Contact Rating:</b>
0.4A @ 125VAC
2A @ 30VDC

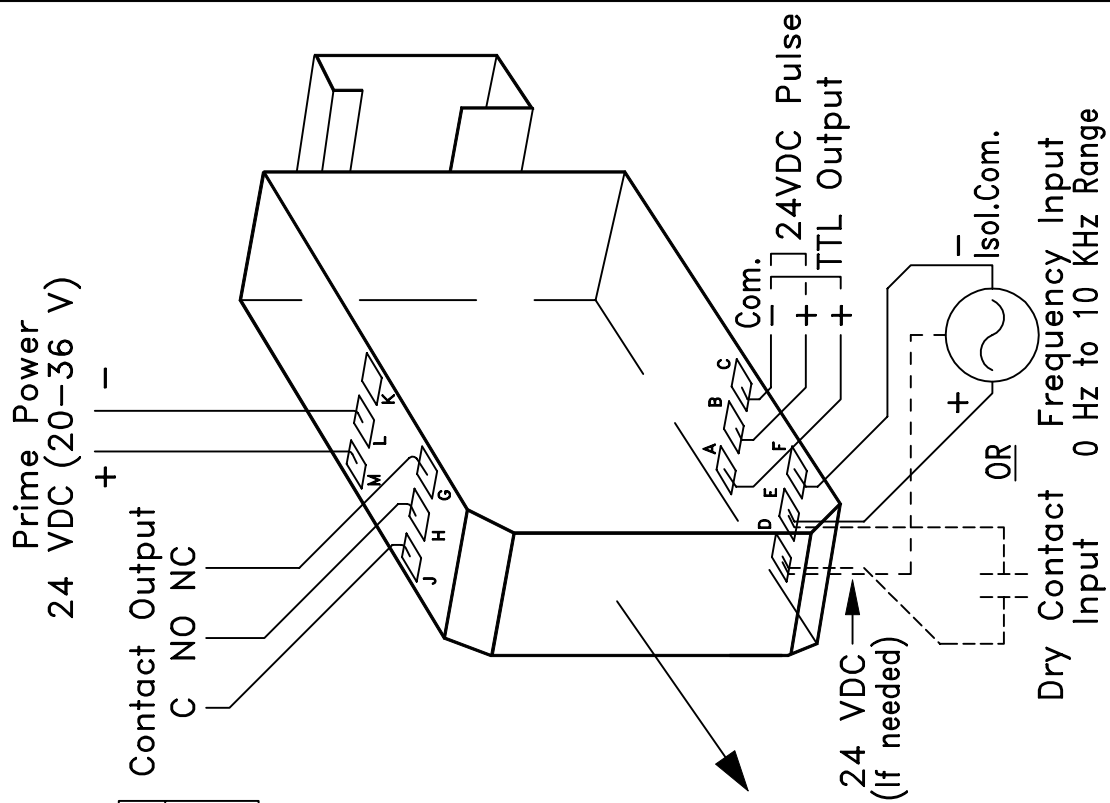
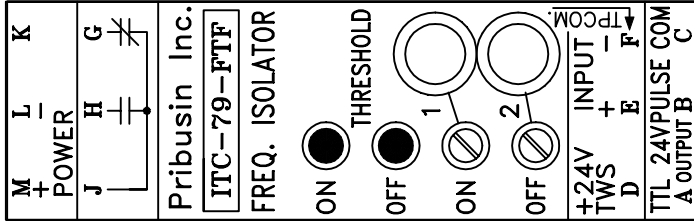

**Notes:**

1. For Details of Terminal Block Enclosure/Din Rail See Dwg. 104385.

<b>Pribusin Inc. ©</b>		
<b>CHKD :</b>	<b>DATE :</b> SEPT. 23/94	<b>DRN :</b> KS
<b>Model: ITC-79-FTF</b> <b>Frequency Isolator</b> <b>Connection Diagram</b>		
<b>DWG. NO. :</b>	105132	<b>REV. B</b>

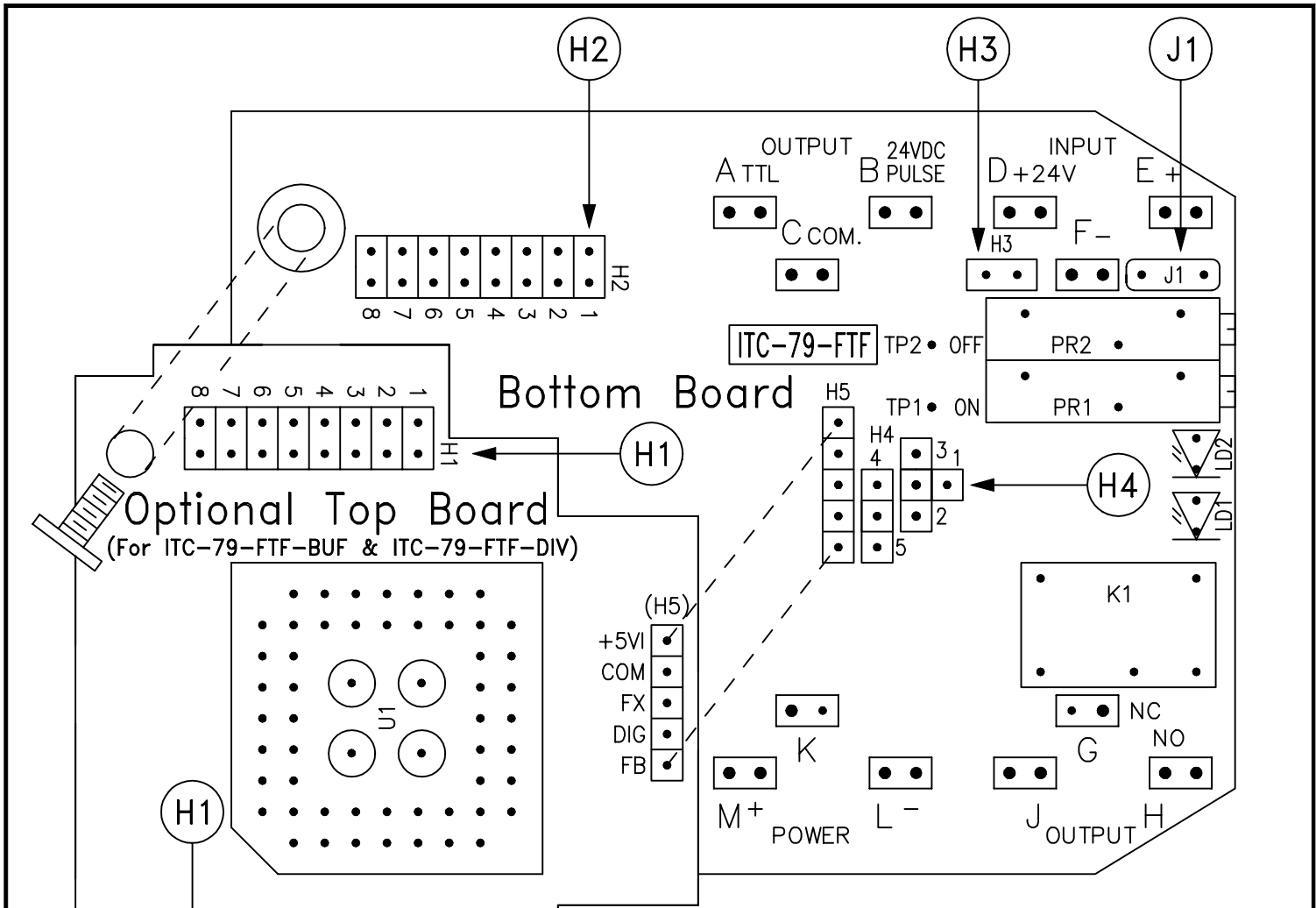

JUMPER	FUNCTION
H4-1 IN	(FX) RELAY & 24VPULSE FOLLOW INPUT DIRECTLY
H4-2 IN	(FB) RELAY & 24VPULSE DRIVEN BY BUFFER
H4-3 IN	(FO) RELAY & 24VPULSE ARE SAME AS TTL
H4-4 IN	(DIR) TTL OUTPUT FOLLOWS INPUT DIRECTLY
H4-5 IN	(DIG) TTL OUTPUT DRIVEN BY BUFFER

JUMPER	FUNCTION
H2-1 IN	10uS
H2-2 IN	100uS
H2-3 IN	1mS
H2-4 IN	10mS
H2-5 IN	10mV
H2-6 IN	100mV
H2-7 IN	1V
H2-8 IN	10V
H3 IN	10KOhm INPUT IMPEDANCE
J1 = JUMPER	DC COUPLING
J1 = 1uF CAP.	AC COUPLING

**NOTE:**

FOR DETAILS OF CALIBRATION & SETUP PROCEDURE, SEE DWG 105133.

<b>Pribusin Inc. ©</b>		
CHKD:	DATE: Sept. 23/94	DRN: KS
<b>Model: ITC-79-FTF Frequency Isolator Jumper Locations</b>		
DWG. NO.:	105134	REV. A

## Calibration & Setup Procedure for ITC-79-FTF

(includes ITC-79-FTF-BUF & ITC-79-FTF-DIV)

### 1. Factory Settings: (unless otherwise specified at time of order)

#### ITC-79-FTF:

Input Type: Voltage Input, TTL level (0-5 VDC) (jumper H2-8 inserted)  
Thresholds: ON: TP1 = 3V , OFF: TP2 = 1V  
Relay & 24V Pulse: Follows input directly (jumper H4-1 installed)  
Response Time: 100 microsec. (jumper H2-2 installed)  
TTL Output: Follows input directly (jumper H4-4 installed)

#### ITC-79-FTF-BUF:

Input Type: Voltage Input, TTL level (0-5 VDC) (jumper H2-8 inserted)  
Thresholds: ON: TP1 = 3V , OFF: TP2 = 1V  
Relay & 24V Pulse: Buffered pulse output (jumper H4-2 installed)  
Response Time: 100 microsec. (jumper H2-2 installed)  
TTL Output: Buffered pulse output (jumper H4-5 installed)  
Output Pulse Rate: 500 msec.

#### ITC-79-FTF-DIV:

Input Type: Voltage Input, TTL level (0-5 VDC) (jumper H2-8 inserted)  
Thresholds: ON: TP1 = 3V , OFF: TP2 = 1V  
Relay & 24V Pulse: Divided Output (jumper H4-2 installed)  
Response Time: 100 microsec. (jumper H2-2 installed)  
TTL Output: Divided Output (jumper H4-5 installed)  
Division Factor: 100

### 2. Input Type:

Determine the type of input that is to be applied to the ITC-79-FTF (choices are *Voltage, Dry Contact, AC or DC Coupled*). Follow the instructions below depending on which input type you are using:

#### Voltage Input:

Several input ranges for various voltage levels can be set up by jumpers H2-5 through H2-8. Select only one range and insert only one jumper for that range.

0-10 mV	insert jumper H2-5
0-100 mV	insert jumper H2-6
0-1 V	insert jumper H2-7
0-10 V	insert jumper H2-8

#### Dry Contact Input:

Insert jumper H3 to select a 10 KOhm input impedance. Insert jumper H2-8 to select a 0-10 V input range. Set the ON threshold to +10 V (using TP1) and the OFF threshold to +5 V (using TP2).

#### AC or DC Coupling:

The ITC-79-FTF is set up for DC Coupling by default. To change the input to AC Coupling, remove jumper J1 and replace it with a 1 uF capacitor.

### 3. Input Response Time:

There are four response times to choose from for the input conditioning circuitry. These response times help eliminate noise on the input signal. Choose a response time that is adequate for your particular frequency input. Make sure that the highest frequency that is to be accepted by the input has a period greater than the chosen response time.

10 msec	insert jumper H2-4
---------	--------------------

1 msec                    insert jumper H2-3  
 100 microsec            insert jumper H2-2  
 10 microsec insert jumper H2-1

For Example, if the maximum frequency is 2000 Hz, the period is 1/2000 sec. or 500 micro seconds. Choose either 100 micro seconds or 10 micro seconds. If you were to choose 1 msec or 10 msec, the input could not respond fast enough to your highest input frequency and the ITC-79-FTF would not accept the input.

#### 4. ON & OFF Thresholds:

The ITC-79-FTF has two threshold settings: one for the ON level (rising edge of the input) and one for the OFF level (falling edge of the input). These threshold levels must be set such that the amplitude of the input signal is larger than that of the ON and OFF threshold levels. The ON and OFF LED's indicate which portion of the pulse is currently being received (on frequencies above 30 Hz, both LED's appear to be on simultaneously).

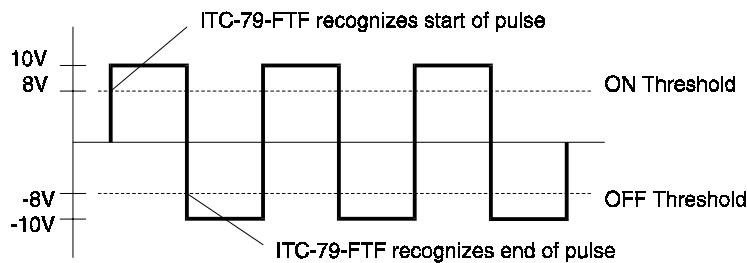

In the above example, the input signal swings from -10V to + 10V. A good threshold level is at -8V and +8V to eliminate any possible ringing noise at the rising and falling edges. For a dry contact input, choose an OFF Threshold above 0V, say 10-20% of the full scale signal.

To set the Threshold levels, use a voltmeter between TP1 and TPCOM for the ON Threshold and adjust the multiturn potentiometer until the meter reads the desired level. Do the same for the OFF Threshold using TP2 and TPCOM.

Note: If you are using an input range other than 10 V, the Threshold levels of +/- 10V represent -100% to +100% of the selected input range. For example, a threshold of 8V represents 80 mV on a 100mV input range setting.



## 5. Output Type:

The ITC-79-FTF has three standard output types. These are Dry Contact, TTL (5V), and 24 VDC. To activate the TTL output, jumper H4-4 must be inserted (factory default setting). To activate the relay and 24 VDC output, jumper H4-1 must be inserted. All outputs can be used simultaneously.

The 24 VDC output is a 'straight through' output which means that it follows the incoming signal directly (i.e. when the input goes high the 24 VDC output goes high, etc.). The TTL output is inverted ! (i.e. when the input goes high, the TTL output goes low and vice versa).

## 6. Additional Setup & Calibration for ITC-79-FTF-BUF only:

The ITC-79-FTF-BUF stores incoming pulses (frequency) in an internal buffer in its microprocessor and releases them at a slower rate as a 50% duty cycle square wave. The output pulse release rate is adjustable from immediate output (no buffering) to 6.5 second pulse durations in 0.1 msec intervals. The pulse release rate is set up using the jumper strip H1. The release time is encoded in binary which means that up to 65536 ( $2^{16}$ ) combinations of release rates are selectable. Jumper position H1-1 is equivalent to 0.1 msec, position H1-2 equals 0.2 msec, H1-3 equals 0.4 msec all the way to H2-16 which equals 3276.8 msec (3.2768 sec.).

Example: for an output pulse rate of 1/2 second (500 msec.) the jumpers on H1 have to be as follows.

H1-1 out	H1-5 out	H1-9 in	H1-13 in
H1-2 out	H1-6 out	H1-10 in	H1-14 out
H1-3 out	H1-7 out	H1-11 out	H1-15 out
H1-4 out	H1-8 in	H1-12 out	H1-16 out

The jumpers that are inserted carry the binary weights of 0.8+12.8+25.6+51.2+409.6 which when added together, results in 500.0 msec

### Output Selection:

The ITC-79-FTF-BUF can be configured as a 'straight through' instrument or a pulse buffer or a combination of both. Jumpers H4-1,2,3 control the relay output and jumpers H4-4,5 control the TTL output. The following tables show how the different jumpers affect the operation of the outputs:

	Relay	TTL Output
H4-1	Relay & 24 VDC follow input directly	H4-4 TTL Output follow
H4-2	Relay & 24 VDC driven by buffer	H4-5 TTL Output driven by
H4-3	Relay & 24 VDC issame as TTL output (depending on H4-4,5)	

## 7. Additional Setup & Calibration for ITC-79-FTF-DIV only:

The ITC-79-FTF-DIV takes the incoming pulses (frequency) and provides a 50% duty cycle square wave output that is divided by an adjustable division factor. The division factor can be in the range of 1 to 65535 and is encoded in binary on the jumper strip H1. Position H1-1 carries the weight 1, H1-2 equals 2, H1-3 equals 4, all the way to H1-16 which equals 32768. As division by 0 is invalid, the output will stop if no division factor is set up on H1.

Example: to divide the input by 1000 the jumpers on H1 must be set as follows:

H1-1 out	H1-5 out	H1-9 in	H1-13 out
H1-2 out	H1-6 in	H1-10 in	H1-14 out
H1-3 out	H1-7 in	H1-11 out	H1-15 out
H1-4 in	H1-8 in	H1-12 out	H1-16 out

The jumpers that are inserted carry the binary weights of  $8+32+64+128+256+512$  which when added together, results in 1000.

### Output Selection:

The ITC-79-FTF-DIV can be configured as a 'straight through' instrument or a divider or a combination of both. Jumpers H4-1,2,3 control the relay output and jumpers H4-4,5 control the TTL output. The following tables show how the different jumpers affect the operation of the outputs:

	Relay	TTL Output
H4-1	Relay & 24 VDC follow input directly	H4-4 TTL Output follow
H4-2	Relay & 24 VDC driven by divider	H4-5 TTL Output driven by
H4-3	Relay & 24 VDC is same as TTL output (depending on H4-4,5)	

## Enclosure Detail :

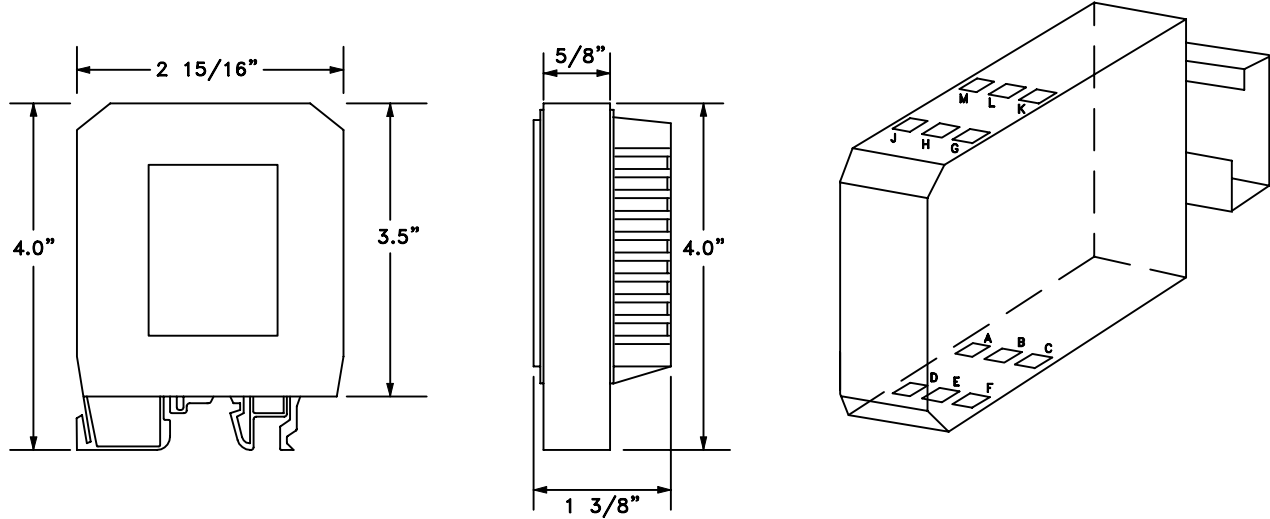

## Din Rail Detail :

	<p><b>A</b></p> <p>Rail Standard EN 50 035 Dimensions: 32 x 15 x 1.5 mm</p>
	<p><b>B</b></p> <p>Rail Standard DIN EN 50 022 Dimensions: 35 x 15 x 2.3 mm</p>
	<p><b>C</b></p> <p>Rail Standard DIN EN 50 022 Dimensions: 35 x 7.5 x 1 mm</p>
	<p><b>D</b></p> <p>Rail Standard DIN EN 50 022 Dimensions: 35 x 15 x 1.5 mm</p>

<p><b>Pribusin Inc. ©</b></p>		
CHKD:	DATE: APR. 26/93	DRN: KS
<p>(Wide Cover) Terminal Block Enclosure/ Din Rail Detail</p>		
DWG. NO. :	104385	REV. B