



*Manufacturers of Process  
Controls and Instrumentation*

# ***Instruction Manual***

Model: *IUC-7X-RMS-XXY*

Function: *Isolated RMS Voltage/Current Conditioner*

Input:  ACI: 0-5 AAC       ACV: 0-150 VAC  
 DCI: 0-5 ADC       DCV: 0-150 VDC

\_\_\_\_\_

Output:  X=1: 1-5 mA       X=4: 10-50 mA  
 X=2: 4-20 mA       X=5: 1-5 VDC  
 X=3: 0-1 mA       X=6: 0-10 VDC

X=7: \_\_\_\_\_

Power:  117 VAC, 60 Hz, 6 VA  
 24 VDC, 160 mA  
 \_\_\_\_\_

Serial #: \_\_\_\_\_

(If special or required)

For Technical Assistance And Questions Call  
USA: (231) 788-2900    CANADA: (905) 660-5336

## Restocking Policy

**All product returned to Pribusin Inc. in prime condition (not damaged, scratched or defaced in any way) within seven (7) months from the original date of shipment is subject to a 50% restocking charge. All product must be accompanied by a Return Authorization number (RA number) which must be obtained from Pribusin Inc. prior to returning any product.**

**After seven (7) months from the original date of shipment, products cannot be returned for restocking.**

**Custom designed products, modified products or all non-standard products may not be returned for restocking.**

## Warranty Policy

**Pribusin Inc. warrants equipment of its own manufacture to be free from defects in material and workmanship, under normal conditions of use and service, and will replace any component found to be defective, on its return to Pribusin Inc., transportation charges prepaid, within one year of its original purchase. Pribusin Inc. will extend the same warranty protection on equipment, peripherals and accessories which is extended to Pribusin Inc. by the original manufacturer. Pribusin Inc. also assumes noliability, expressed or implied, beyond its obligation to prelace any component involved. Such warranty is in lieu of all other warranties, expressed or implied.**



**Standard Features:**

- High Input-Output-Power Isolation (1500VAC Test)
- Industry Standard Inputs: 0-5 Amps or 150 Volts AC or DC (see back)
- Industry Standard Output: 4-20 mA, 1-5 VDC, more (see back)
- High Output Drive on Current Outputs
- Easy Field Calibration (Typ. calibration time < 2 min. using handheld meter only)
- Microprocessor Controlled for High Accuracy
- Power: 117 VAC 50/60 Hz (Optional 24 VDC)
- High Noise Rejection
- CSA and NRTL Approved (LR 51078)

**Function:**

The IUC-7X-RMS-XXY is a microprocessor controlled RMS converter. It comes in a DC and in an AC configuration for either current or voltage measurement. In the DC configuration, the instrument computes the RMS value of both the DC and the AC component of the input signal. In the AC configuration, the input is capacitively coupled so that the DC component is blocked and only the AC component is used to determine the RMS value.

Both configurations sample the input waveform 2500 times to compute the true RMS value. This ensures great accuracy and allows for accurate RMS value measurement of odd shaped waveforms. The output is updated every 0.625 seconds

**CAUTION:** When using AC current we recommend using the ACI-CT current transformer for dangerous over-voltage protection.

**Calibration:**

An input span adjustment allows for field adjustments of the 100% input value. The input span can be in the range of 0-100% and can be read with a voltmeter at its test point. The test point shows a voltage of 0-5 VDC for an input of 0-100%.

**Specifications:**

- Isolation: Input to Output to Power 1500 VAC (test)
- Accuracy/Linearity: +/- 0.3% max., +/- 0.1% typ.
- Operating Temperature: -40 Deg.C. to +50 Deg.C.
- Temperature Effects: +/-0.5% max., +/-0.2% typ. (for 40 Deg.C. change)

# IUC-7X-RMS-XXY

## Enclosures & Dimensions:

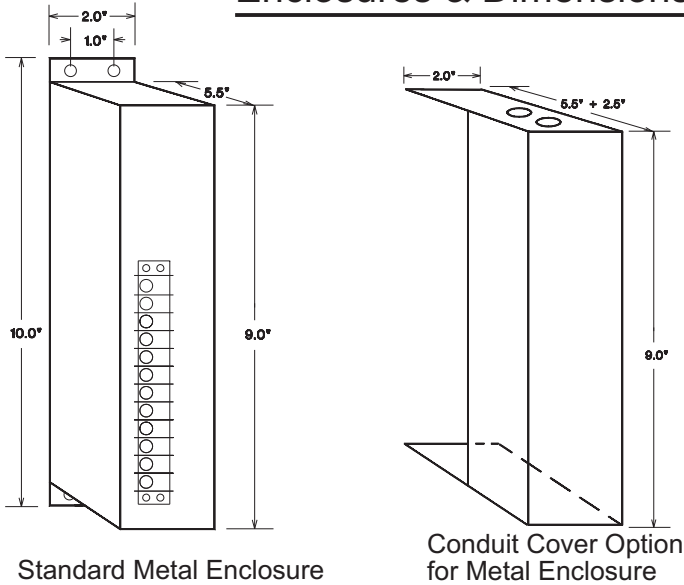

## CAUTION

When measuring AC current we strongly recommend using the ACI-CT Current Transformer. This reduces the 0-5 AAC to a safe 0-5 mA AC which is protected for accidental open circuiting. This changes the IUC-7X-RMS-ACV to a 0-5mA input device. If the ACI-CT is omitted on such an instrument dangerously high voltages will occur when directly connecting a 0-5 AAC input to the instrument.

The secondary of the ACI-CT may be open circuited without any dangerous voltages appearing. NEVER open circuit the primary of the ACI-CT without taking proper current transformer shorting measures.

## Connection:

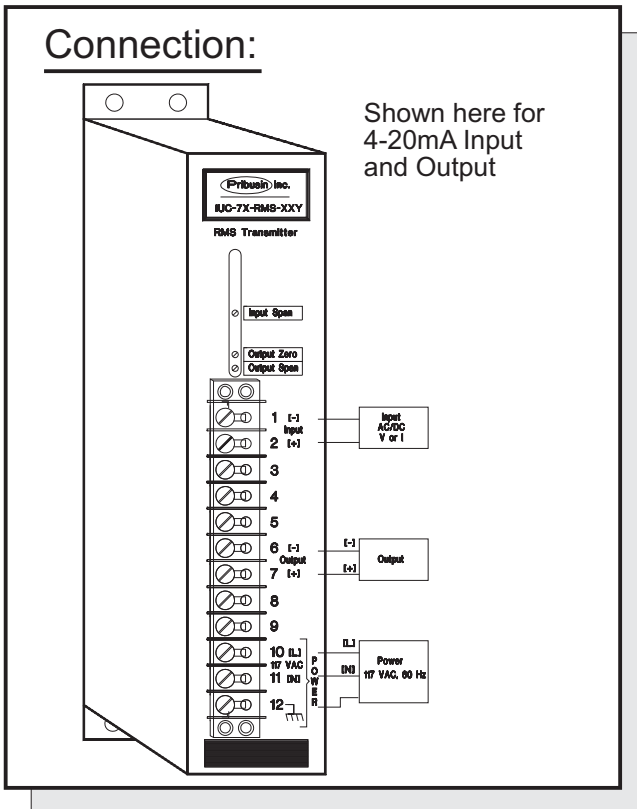

## Model Designation:

IUC-7X-RMS-XXY

Output

Input

- 1: 1-5 mA (4000 Ohm Drive)
- 2: 4-20 mA (1000 Ohm Drive)
- 3: 0-1 mA (20000 Ohm Drive)
- 4: 10-50 mA (250 Ohm Drive)
- 5: 1-5 VDC (Zout=250 Ohm)
- 6: 0-10 VDC (Zout=500 Ohm)
- 7: Special Output

- ACI: 0-5 Amps AC
- DCI: 0-5 Amps DC
- ACV: 0-150 VAC
- DCV: 0-150 VDC

Example: RMS converter with 150 VAC input and 4-20 mA Output in standard metal enclosure and 117 VAC Power is designated by: IUC-72-RMS-ACV

If no options specified, unit is 117 VAC Power in metal enclosure

## Options: (Add letters to end of Model Number)

- A - 24 VDC Prime Power
- B - 240 VAC Prime Power (not CSA approved)
- C - Conduit Cover for Metal Enclosure (see above)
- N - NEMA 4X enclosure (see above)
- Model: ACI-CT Safe Current Transformer (0-5 mA)

Manufactured By:

**Pribusin Inc.**

www.pribusin.com  
info@pribusin.com

### USA:

Pribusin Inc.  
743 Marquette Ave.  
Muskegon, MI 49442  
Ph: (231) 788-2900  
Fx: (231) 788-2929



### CANADA:

Pribusin Inc.  
101 Freshway Dr. Unit 57  
Concord, Ontario, L4K 1R9  
Ph: (905) 660-5336  
Fx: (905) 660-4068

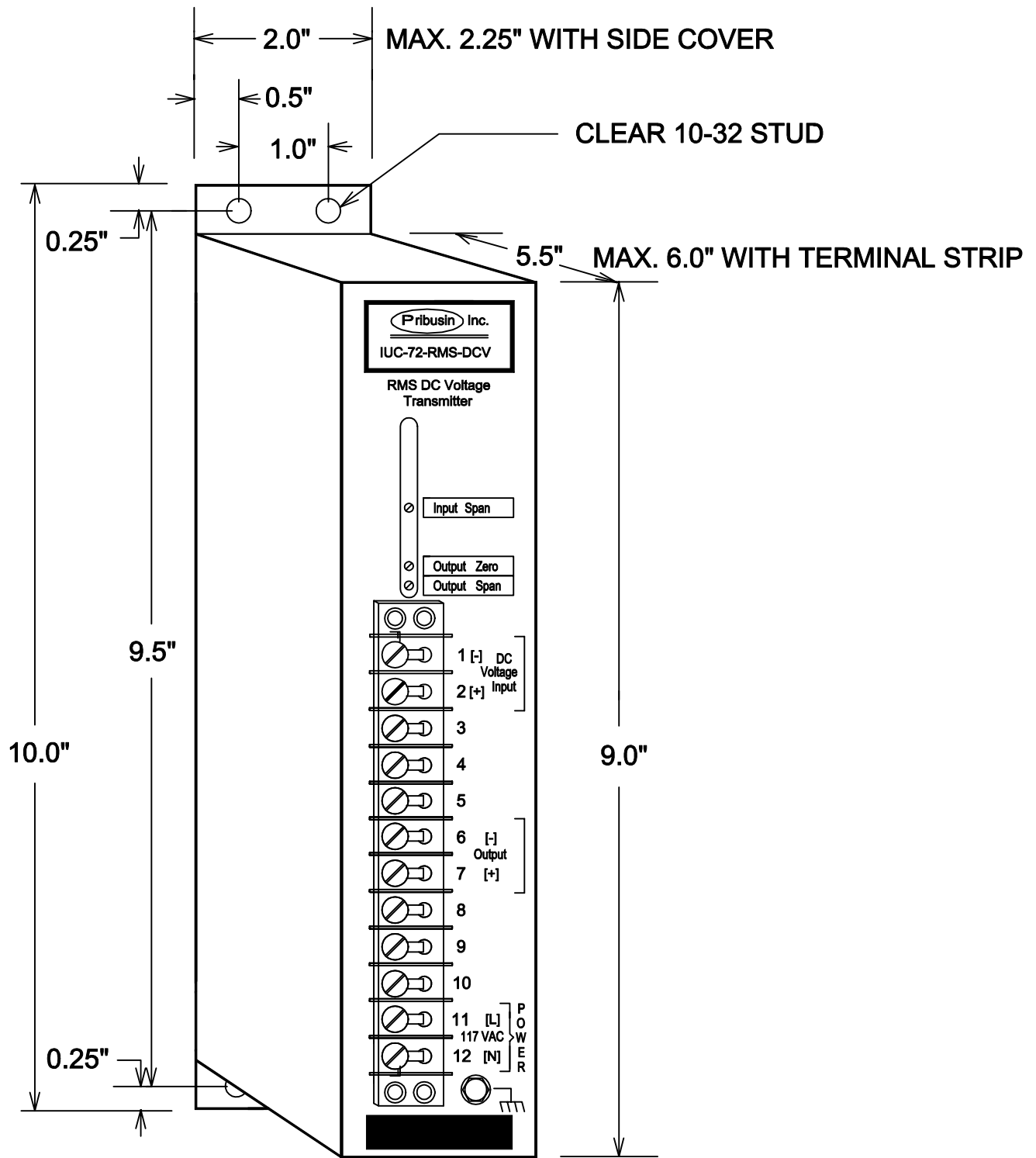

Rev. B Mar. 21/96 by KS

**Pribusin Inc. ©**

CHKD: DATE: AUG. 31/92 DRN: KS

Model: IUC-72-RMS-DCV  
RMS DC Voltage Transmitter  
Enclosure Drawing

DWG. NO.: 103999 REV. B

## Calibration Procedure :

Note : Instrument has been factory calibrated and normally needs no adjustments.

Connect instrument as shown in diagram.

1. Put in jumper 6(H1). See Detail A.
2. Adjust OUTPUT ZERO until output signal is 4 mA.
3. Move jumper to 7(H1).
4. Adjust OUTPUT SPAN until output signal is 20 mA.
5. Repeat procedure starting at 1. until output signal is correct.
6. Remove jumper from 7(H1).
7. Turn INPUT SPAN clockwise 25 turns.
8. To set input span, apply a 100% input signal (exactly) and slowly turn INPUT SPAN counter-clockwise until the output signal drops just below 20 mA. Then turn clockwise until the output signal is just 20 mA.

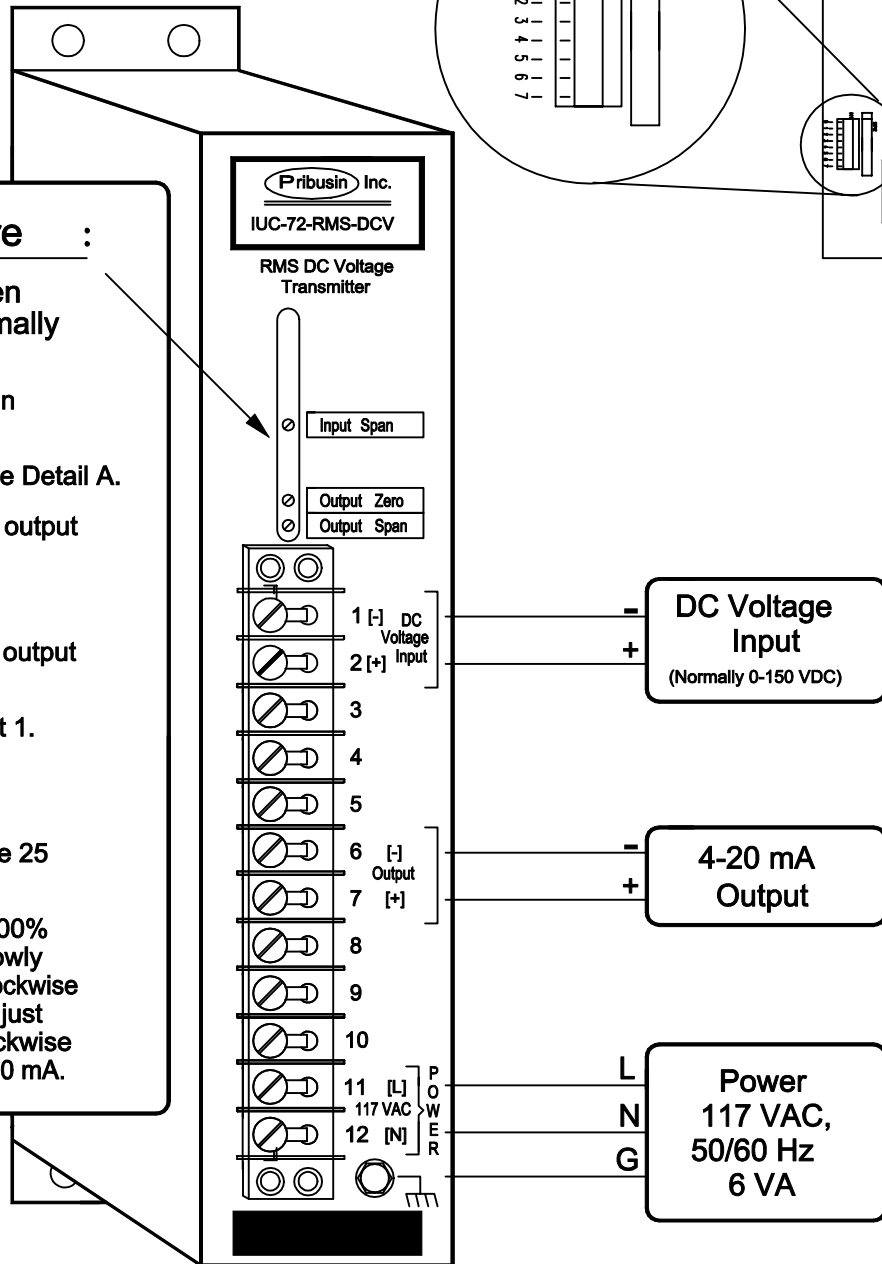

Rev. B Mar. 21/96 by KS

<b>Pribusin Inc. ©</b>		
CHKD:	DATE: AUG. 31/92	DRN: KS
Model: IUC-72-RMS-DCV RMS DC Voltage Transmitter Connections/Calibration		
DWG. NO. :	104000	REV. B