



*Manufacturers of Process
Controls and Instrumentation*

Instruction Manual

Model: ***IUC-7X-RXC-N (NEMA 4X)***

Function: ***Telephone Line Transmission System***

Input: Leased Phone Line (600 Ohm)
(from IUC-X9-TXC)

Output: ***One Analog and 2 Dry Contacts***

- | | |
|--------------------------------------|--|
| <input type="checkbox"/> X=1: 1-5mA | <input type="checkbox"/> X=4: 10-50mA |
| <input type="checkbox"/> X=2: 4-20mA | <input type="checkbox"/> X=5: 1-5 VDC |
| <input type="checkbox"/> X=3: 0-1 mA | <input type="checkbox"/> X=6: 0-10 VDC |
| <input type="checkbox"/> X=7: _____ | |

Power: 117 VAC, 50/60 Hz

24 VDC, 160 mA

Serial #: _____

(If special or required)

For Technical Assistance And Questions Call
USA: (734) 677-0459 CANADA: (905) 660-5336

Restocking Policy

All product returned to Pribusin Inc. in prime condition (not damaged, scratched or defaced in any way) within seven (7) months from the original date of shipment is subject to a 50% restocking charge. All product must be accompanied by a Return Authorization number (RA number) which must be obtained from Pribusin Inc. prior to returning any product.

After seven (7) months from the original date of shipment, products cannot be returned for restocking.

Custom designed products, modified products or all non-standard products may not be returned for restocking.

Warranty Policy

Pribusin Inc. warrants equipment of its own manufacture to be free from defects in material and workmanship, under normal conditions of use and service, and will replace any component found to be defective, on its return to Pribusin Inc., transportation charges prepaid, within one year of its original purchase. Pribusin Inc. will extend the same warranty protection on equipment, peripherals and accessories which is extended to Pribusin Inc. by the original manufacturer. Pribusin Inc. also assumes noliability, expressed or implied, beyond its obligation to prelace any component involved. Such warranty is in lieu of all other warranties, expressed or implied.



Standard Features:

- High Input-Output-Power Isolation (1500VAC Test)
- Industry Standard Inputs: 4-20 mA, 1-5 VDC, and more (see below)
- Industry Standard Output: 4-20 mA, 1-5 VDC, more (see below)
- Send One Analog and Two Contacts over Class C Telephone Line
- Easy Field Calibration
- Microprocessor Controlled for High Accuracy
- Two Wire Supply Option for Two Wire Transmitters
- Power: 117 VAC 50/60 Hz (Optional 24 VDC)
- High Noise Rejection
- CSA and NRTL Approved (LR 51078)

Function:

The IUC-X9-TXC is a telephone line transmitter which takes in one analog signal and two dry contacts. It has a 600 Ohm impedance matched output which can connect directly into a class C telephone line. All three signals are sent simultaneously to the IUC-7X-RXC telephone line receiver where they are split up into their original forms. The IUC-7X-RXC also has an impedance matched input to allow direct connection to the phone line. A built in line monitor detects line failures and sets the output to 4 mA.

Specifications:

Isolation: Input to Output to Power 1500 VAC (Test)
Accuracy/Linearity: +/- 0.3% max., +/- 0.1% typ.
Operating Temperature: -40 Deg.C. to + 50 Deg.C.
Temperature Effects: +/- 0.5% max., +/-0.2% typ.
(for 40 Deg. change)

Model Designation:

IUC-X9-TXC

Input

- 1: 1-5 mA (Zin=1K Ohm)
- 2: 4-20 mA (Zin=250 Ohm)
- 3: 0-1mA (Zin=5K Ohm)
- 4: 10-50 mA (Zin=100 Ohm)
- 5: 1-5 VDC (Zin=1Meg Ohm)
- 6: 0-10 VDC (Zin=1Meg Ohm)
- 7: Special Input

IUC-7X-RXC

Output

- 1: 1-5 mA (4000 Ohm Drive)
- 2: 4-20 mA (1000 Ohm Drive)
- 3: 0-1 mA (20000 Ohm Drive)
- 4: 10-50 mA (250 Ohm Drive)
- 5: 1-5 VDC (Zout=250 Ohm)
- 6: 0-10 VDC (Zout=500 Ohm)
- 7: Special Output

Example: A Transmitter/Receiver pair for 4-20 mA input and output with 2 dry contacts in a standard metal enclosure is designated by IUC-29-TXC and IUC-72-RXC.

If no options specified, unit is 117 VAC Power in metal enclosure

Options: (Add letters to end of Model Number)

- A - 24 VDC Prime Power
- B - 240 VAC Prime Power (not CSA approved)
- C - Conduit Cover for Metal Enclosure (see back)
- N - NEMA 4X enclosure (see back)

IUC-X9-TXC & IUC-7X-RXC

Enclosures & Dimensions:

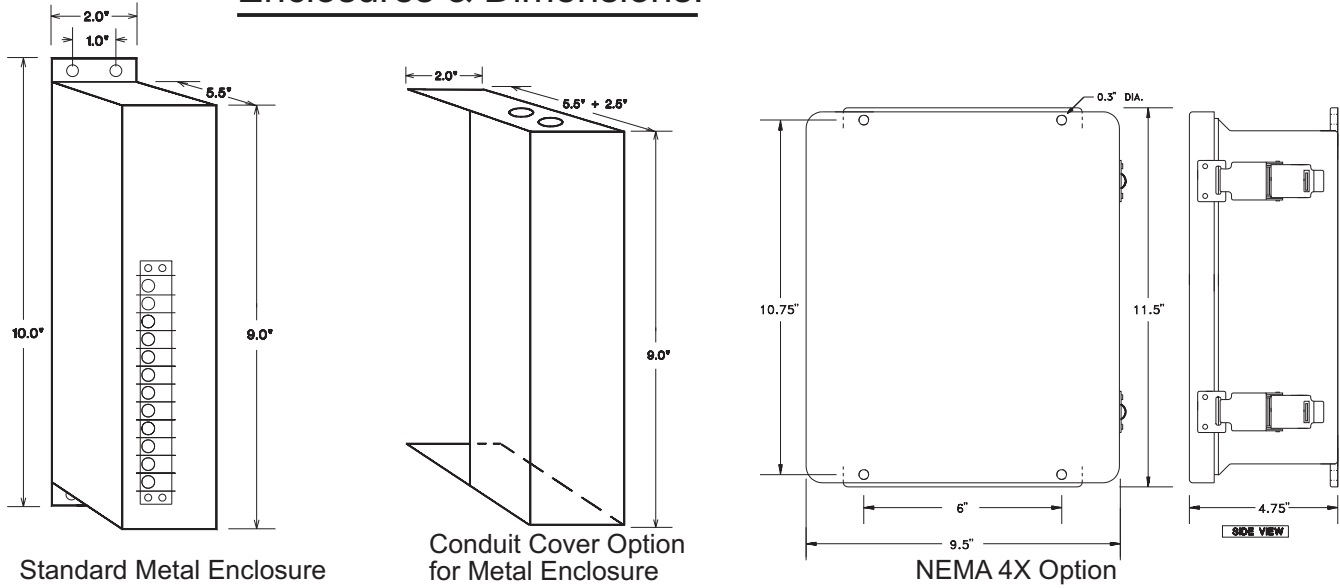

Connection:

Shown here for 4-20mA Input and Output

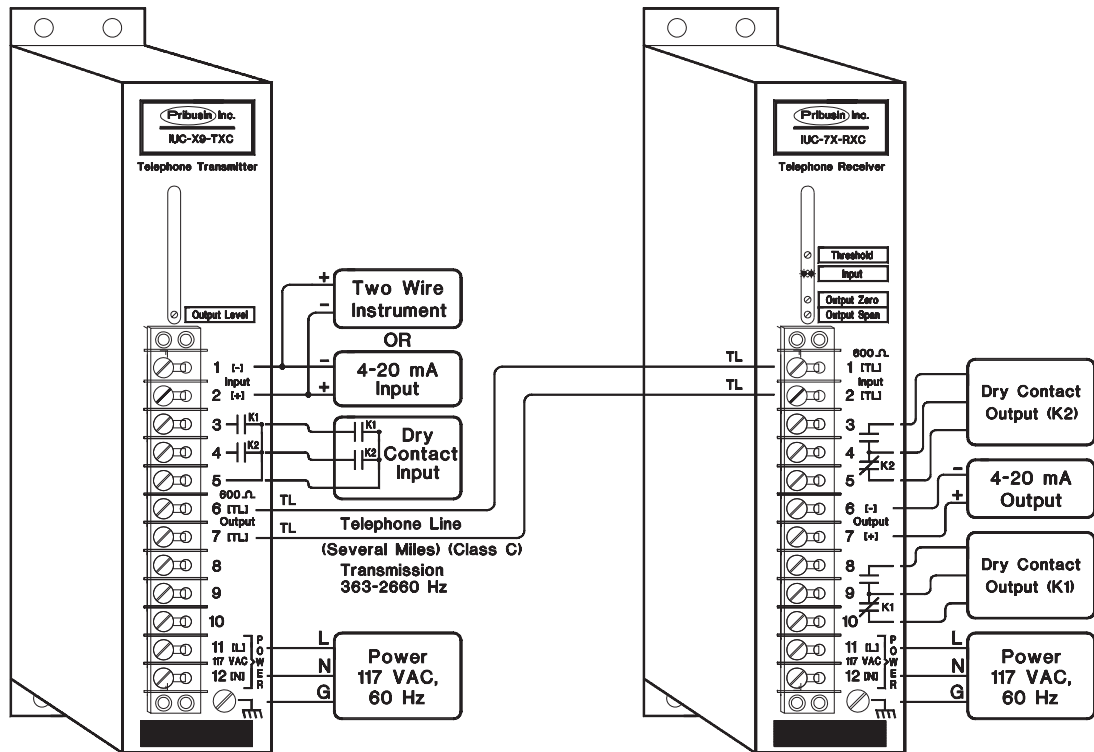

Manufactured By:

Pribusin Inc.

www.pribusin.com
info@pribusin.com

USA:

Pribusin Inc.
 743 Marquette Ave.
 Muskegon, MI 49442
 Ph: (231) 788-2900
 Fx: (231) 788-2929



CANADA:

Pribusin Inc.
 101 Freshway Dr. Unit 57
 Concord, Ontario, L4K 1R9
 Ph: (905) 660-5336
 Fx: (905) 660-4068

0.3" DIA. (QTY 4)

0.3" DIA.

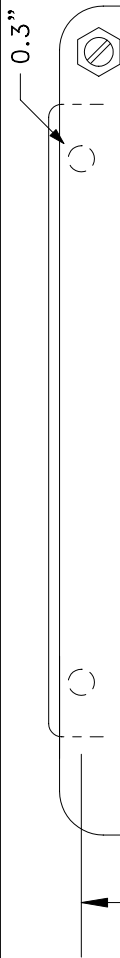

10.75"

11.5"

6"

9.5"

FRONT VIEW

FIBERGLASS ENCLOSURE
WITH STAINLESS STEEL HINGE
AND SCREW COVER

4.75"

SIDE VIEW

Pribusin Inc. ©

CHKD: DATE: AUG. 09/95 DRN: KS

NEMA 4X FIBERGLASS ENCLOSURE
INSIDE SIZE: 10" x 8" x 4"

DWG. NO.: 104499-3

REV. B

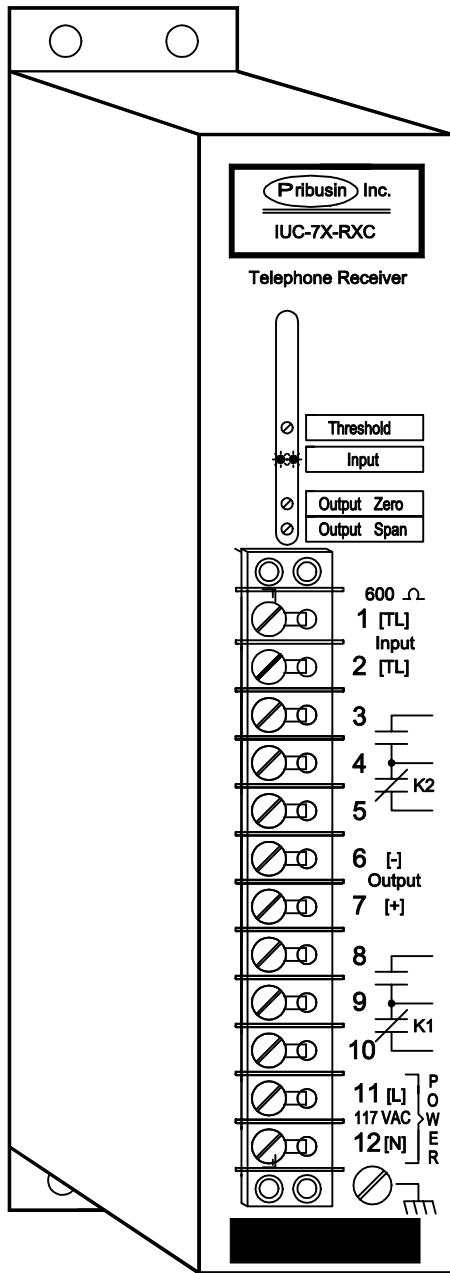

Detail A

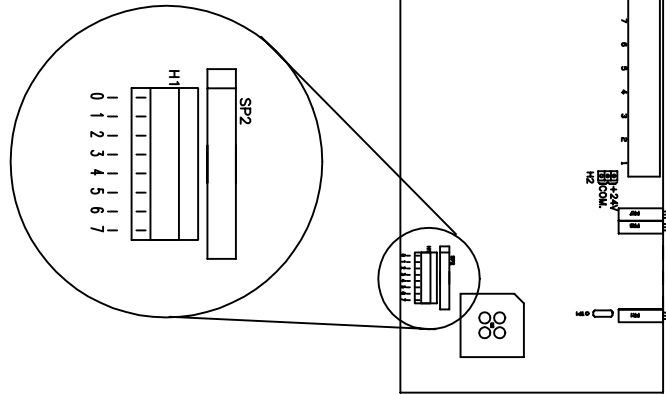

Output Calibration :

1. Put in Jumper 6(H1). See Detail A.
2. Adjust OUTPUT ZERO until output signal is 4 mA.
3. Move Jumper to 7(H1).
4. Adjust OUTPUT SPAN until output signal is 20 mA.
5. Repeat procedure starting at 1. until output signal is correct.
6. Remove Jumper from H1.

Threshold Calibration :

(Threshold is factory set -25 dB, and normally NO adjustment is required.)

With normal input level present,

1. Turn THRESHOLD clockwise until only one LED is ON.
2. Turn THRESHOLD counter clockwise until both LEDs are lit at equal intensity.

See Detail A for Jumper Location

Channel Fail Defaults :		
Jumper	In	Out
H1-5	Output=20mA	Output=4mA
H1-4	K1=Energized	K1=De-energized
H1-3	K2=Energized	K2=De-energized

Pribusin Inc. ©		
CHKD:	DATE: AUG. 11/94	DRN: KS
Model: IUC-7X-RXC Telephone Receiver (363-2660 Hz) Calibration Procedure		
DWG. NO. :	104253	REV. C

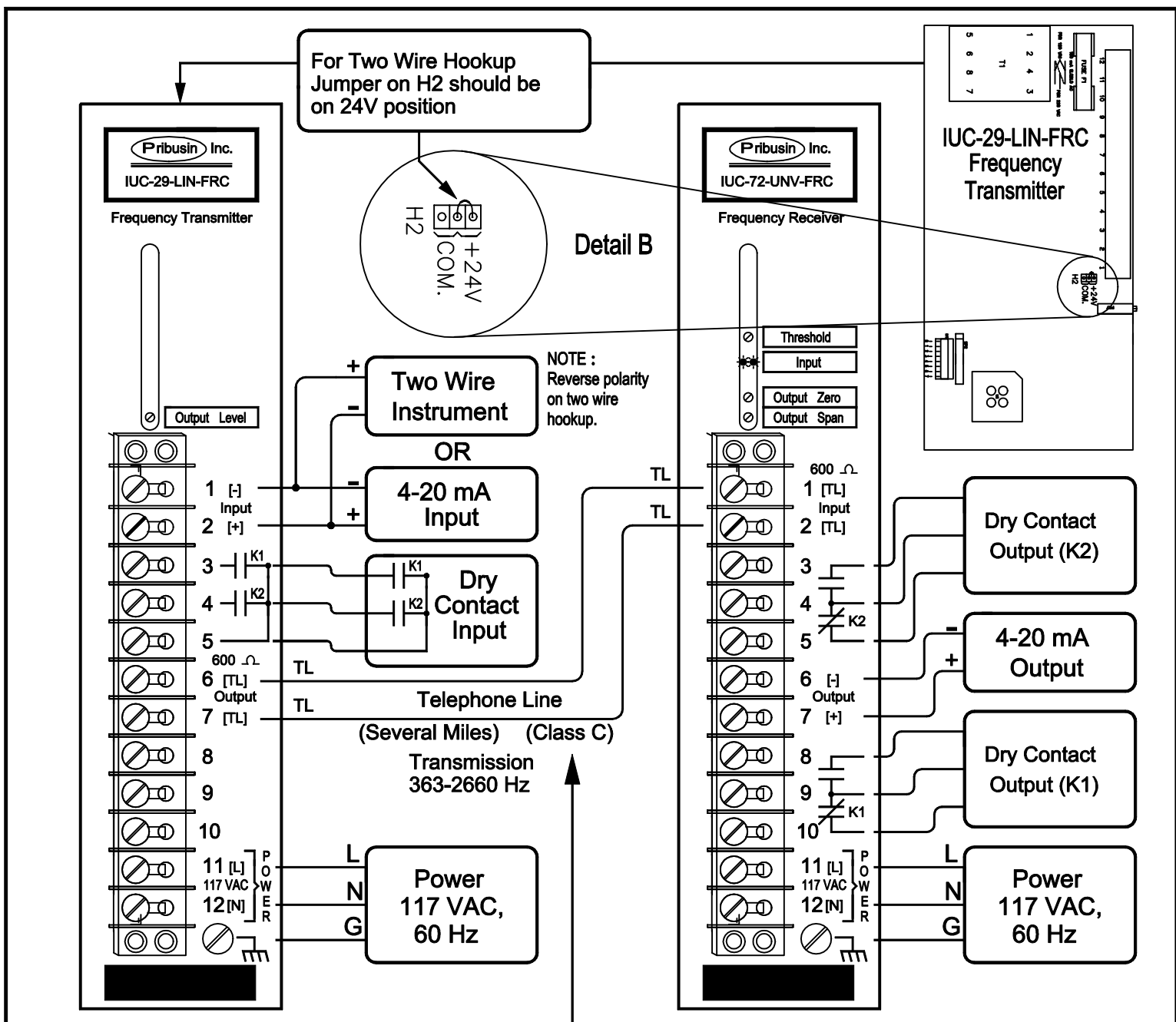

Pribusin Inc. ©

CHKD:	DATE: FEB. 15/93	DRN: KS
Frequency (363-2660 Hz) Telephone System for 4-20 mA Transmission and Two Contacts Connection Diagram		
DWG. NO. :	104255	REV. A