

*Manufacturers of Process  
Controls and Instrumentation*

# ***Instruction Manual***

Model: *IUC-79-FTF*

Function: *Frequency to Frequency Isolator*

Option:  -DIV (Frequency Divider)  
 -BUF (Frequency/Pulse Buffer)

Input:  0-10 VDC  
 \_\_\_\_\_

Thresholds:  ON: TP1=3V      OFF: TP2=1V  
 ON: TP1= \_\_\_      OFF: TP2= \_\_\_

Response Time:  100 microsec.  
 \_\_\_\_\_

Relay:  Not Installed       Installed

Power:  117 VAC, 60 Hz, 6 VA  
 24 VDC, 160 mA  
 \_\_\_\_\_

Serial #: \_\_\_\_\_  
(If special or required)

For Technical Assistance And Questions Call  
USA: (734) 677-0459    CANADA: (905) 660-5336

## Restocking Policy

**All product returned to Pribusin Inc. in prime condition (not damaged, scratched or defaced in any way) within seven (7) months from the original date of shipment is subject to a 50% restocking charge. All product must be accompanied by a Return Authorization number (RA number) which must be obtained from Pribusin Inc. prior to returning any product.**

**After seven (7) months from the original date of shipment, products cannot be returned for restocking.**

**Custom designed products, modified products or all non-standard products may not be returned for restocking.**

## Warranty Policy

**Pribusin Inc. warrants equipment of its own manufacture to be free from defects in material and workmanship, under normal conditions of use and service, and will replace any component found to be defective, on its return to Pribusin Inc., transportation charges prepaid, within one year of its original purchase. Pribusin Inc. will extend the same warranty protection on equipment, peripherals and accessories which is extended to Pribusin Inc. by the original manufacturer. Pribusin Inc. also assumes noliability, expressed or implied, beyond its obligation to prelace any component involved. Such warranty is in lieu of all other warranties, expressed or implied.**



### Standard Features:

- High Input-Output-Power Isolation (1500VAC Test)
- Wide Input Frequency Range (from 0 Hz to 10 KHz)
- Many Input Types & Ranges (Voltage, Dry Contact)
- 4 Standard Outputs (Open Collector, TTL, 12V, 24V)
- Optional Relay Contact Output
- Optional Buffer or Divider Function
- Adjustable Response Time for Noise Rejection
- Easy Field Calibration (Typ. calibration time < 2 min. using handheld meter only)
- Microprocessor Controlled for High Accuracy
- 24 VDC Supply for Dry Contact Input
- Power: 117 VAC 50/60 Hz (Optional 24 VDC)
- CSA and NRTL Approved (LR 51078)

### Function:

The IUC-79-FTF is a Frequency to Frequency Isolator that is easily field configurable to one of many input types such as several voltages or dry contact. Four standard outputs are available (open collector, TTL, 12 VDC, 24 VDC) which can be used individually or simultaneously. Discrete ON and OFF threshold adjustments allow for easy & accurate input signal conditioning. Adjustable response times allow for appropriate signal filtering.

The IUC-79-FTF-BUF is similar to the -FTF but has a microprocessor that can store incoming pulses in a buffer and release them slowly to a slower counting device.

The IUC-79-FTF-DIV is another variation of the -FTF and has the capability to divide the incoming frequency by any number between 1 and 65535.

### Calibration:

The IUC-79-FTF has individual ON and OFF threshold adjustment using multiturn potentiometers. All potentiometers have a test point where a voltage of -10 to +10 VDC indicates the threshold level as -100% to +100%. This allows for easy field calibration with the instrument running.

### Specifications:

- Isolation: Input to Output to Power 1500 VAC (test)
- Operating Temperature: -40 Deg.C. to +50 Deg.C.
- Temperature Effects: +/-0.5% max., 0.2% typ.  
(for 40 Deg.C. change)
- Contact Rating: 10A 1/8Hp @ 125VAC  
6A 1/8Hp @ 277VAC

# IUC-79-FTF

## Enclosures & Dimensions:

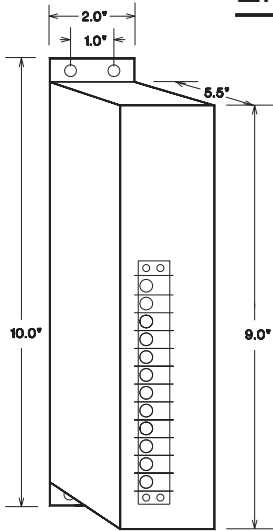

Standard Metal Enclosure

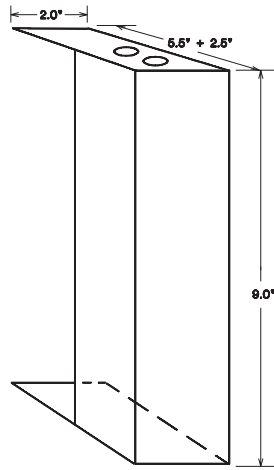

Conduit Cover Option for Metal Enclosure

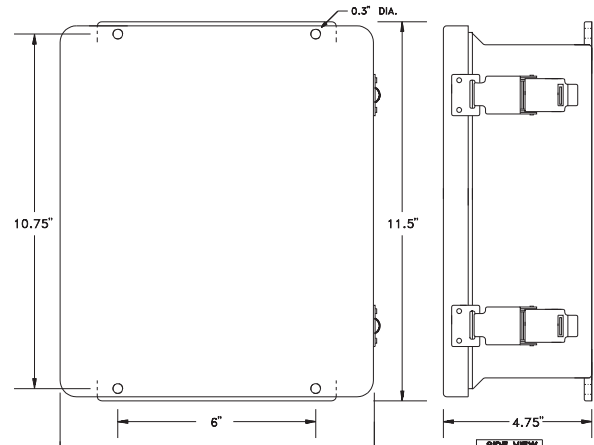

NEMA 4X Option

## Connection:

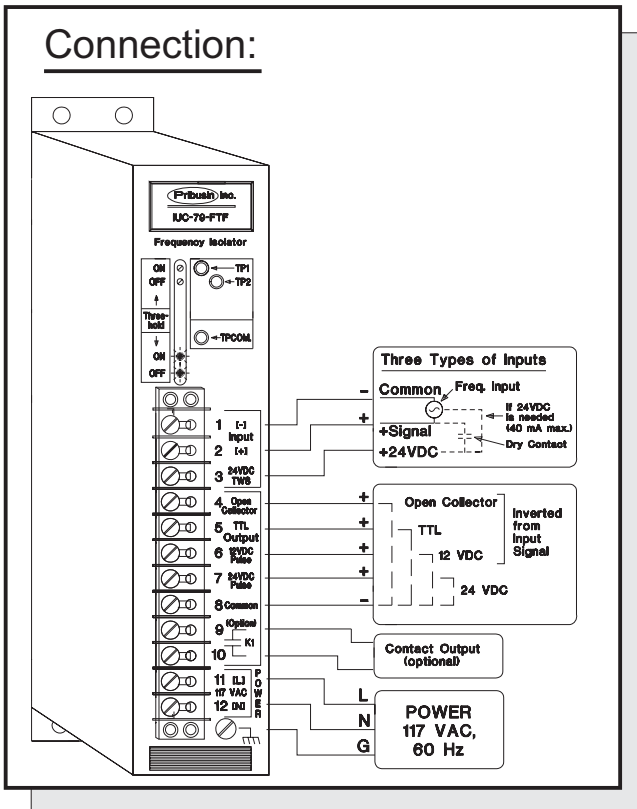

## Available Models:

### IUC-79-FTF: Frequency Isolator

Outputs: Open Collector, TTL, 12VDC, 24VDC  
Optional: Relay Output

### IUC-79-FTF-BUF: Frequency Isolator with Buffer

Outputs: Open Collector, TTL, 12VDC, 24VDC  
Standard: Relay Output  
Function: Store Pulses & Release Slowly

### IUC-79-FTF-DIV: Frequency Isolator with Divider

Outputs: Open Collector, TTL, 12VDC, 24VDC  
Standard: Relay Output  
Function: Divide Input by Division Factor

If no options specified, unit is 117 VAC Power in metal enclosure

## Options: (Add letters to end of Model Number)

- A - 24 VDC Prime Power
- B - 240 VAC Prime Power (not CSA approved)
- C - Conduit Cover for Metal Enclosure (see above)
- N - NEMA 4X enclosure (see above)

Manufactured By:

**Pribusin Inc.**

[www.pribusin.com](http://www.pribusin.com)  
[info@pribusin.com](mailto:info@pribusin.com)

### USA:

Pribusin Inc.  
743 Marquette Ave.  
Muskegon, MI 49442  
Ph: (231) 788-2900  
Fx: (231) 788-2929



### CANADA:

Pribusin Inc.  
101 Freshway Dr. Unit 57  
Concord, Ontario, L4K 1R9  
Ph: (905) 660-5336  
Fx: (905) 660-4068

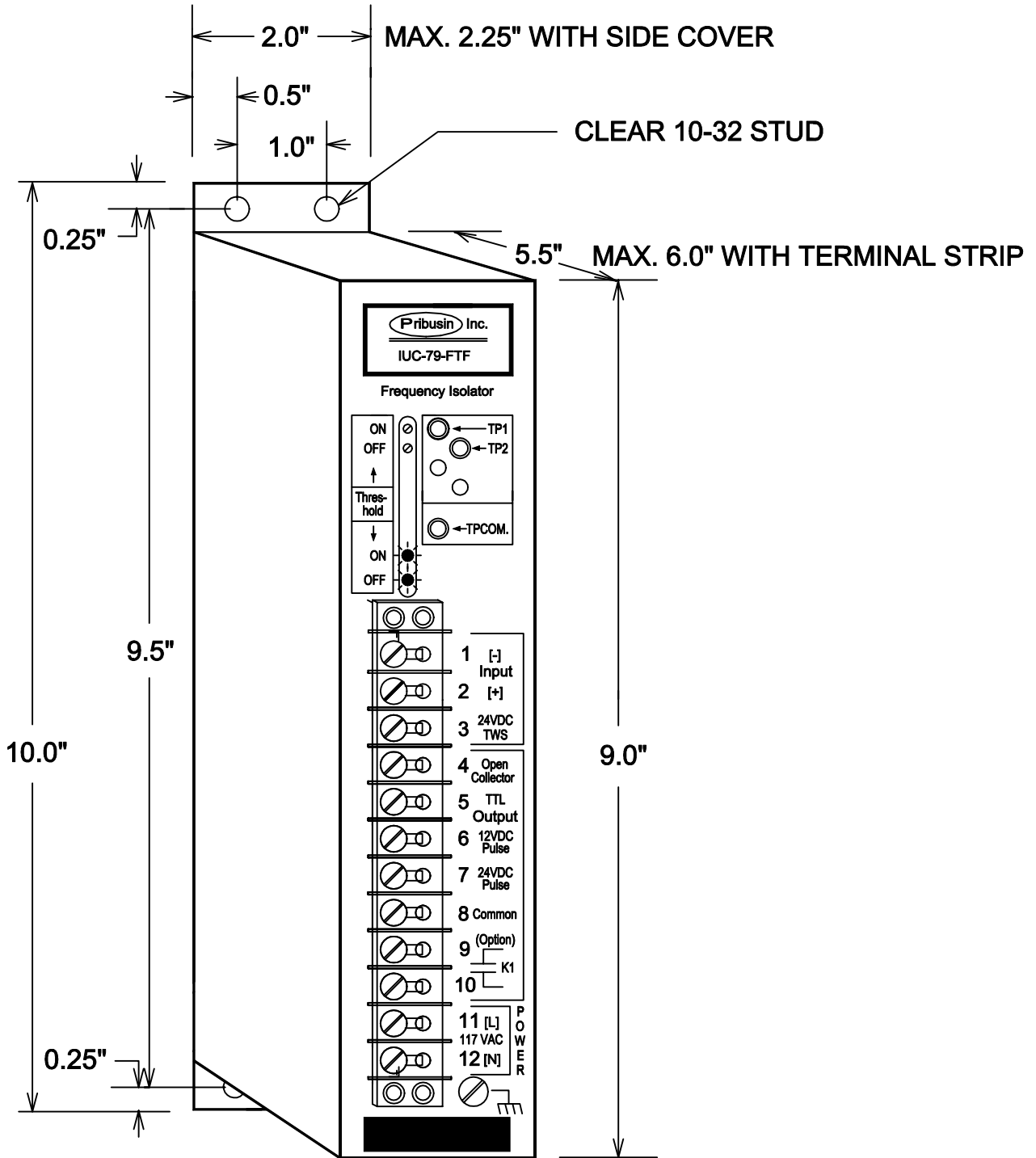

<b>Pribusin Inc. ©</b>		
CHKD:	DATE: JUNE 06/94	DRN: KS
Model: IUC-79-FTF Frequency Isolator Enclosure Drawing		
DWG. NO.:	104962	REV. A

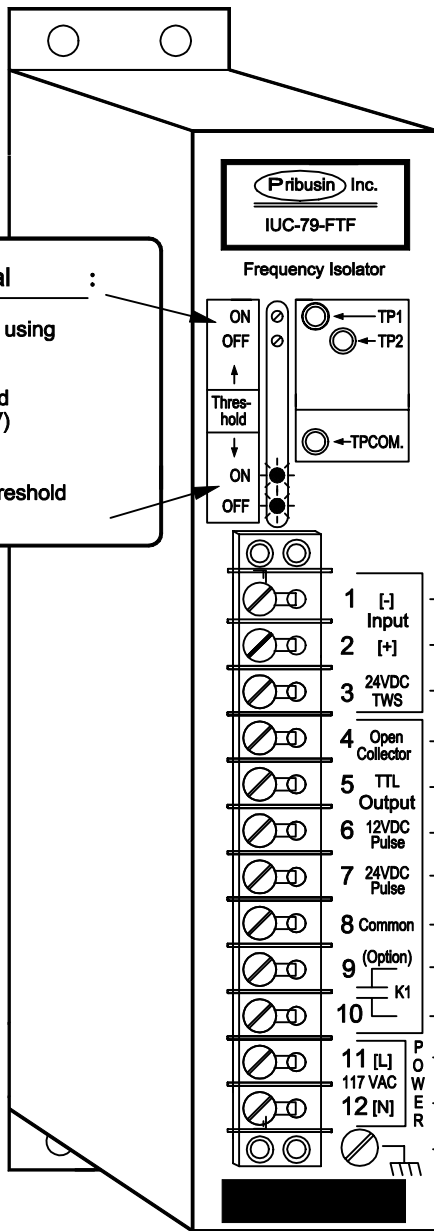

**Threshold adjust for input signal :**

- adjust ON and OFF threshold level using TP1 and TP2.
- TP1 and TP2 will read the threshold level (adjustable from -10V to +10V) representing -100 % to + 100%
- LED's will indicate if ON and OFF threshold levels coincide with input signal.

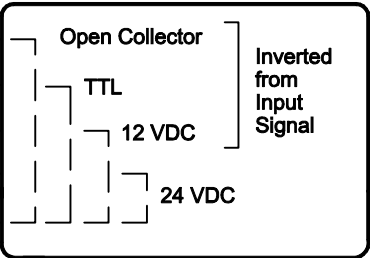
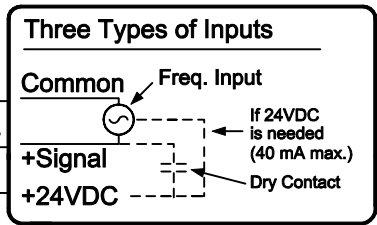

**Contact Output (optional)**

**POWER 117 VAC, 60 Hz**  
L  
N  
G

<b>Pribusin Inc. ©</b>		
CHKD:	DATE: JUNE 06/94	DRN: KS
Model: IUC-79-FTF Frequency Isolator Connections / Calibration		
DWG. NO. :	104963	REV. A

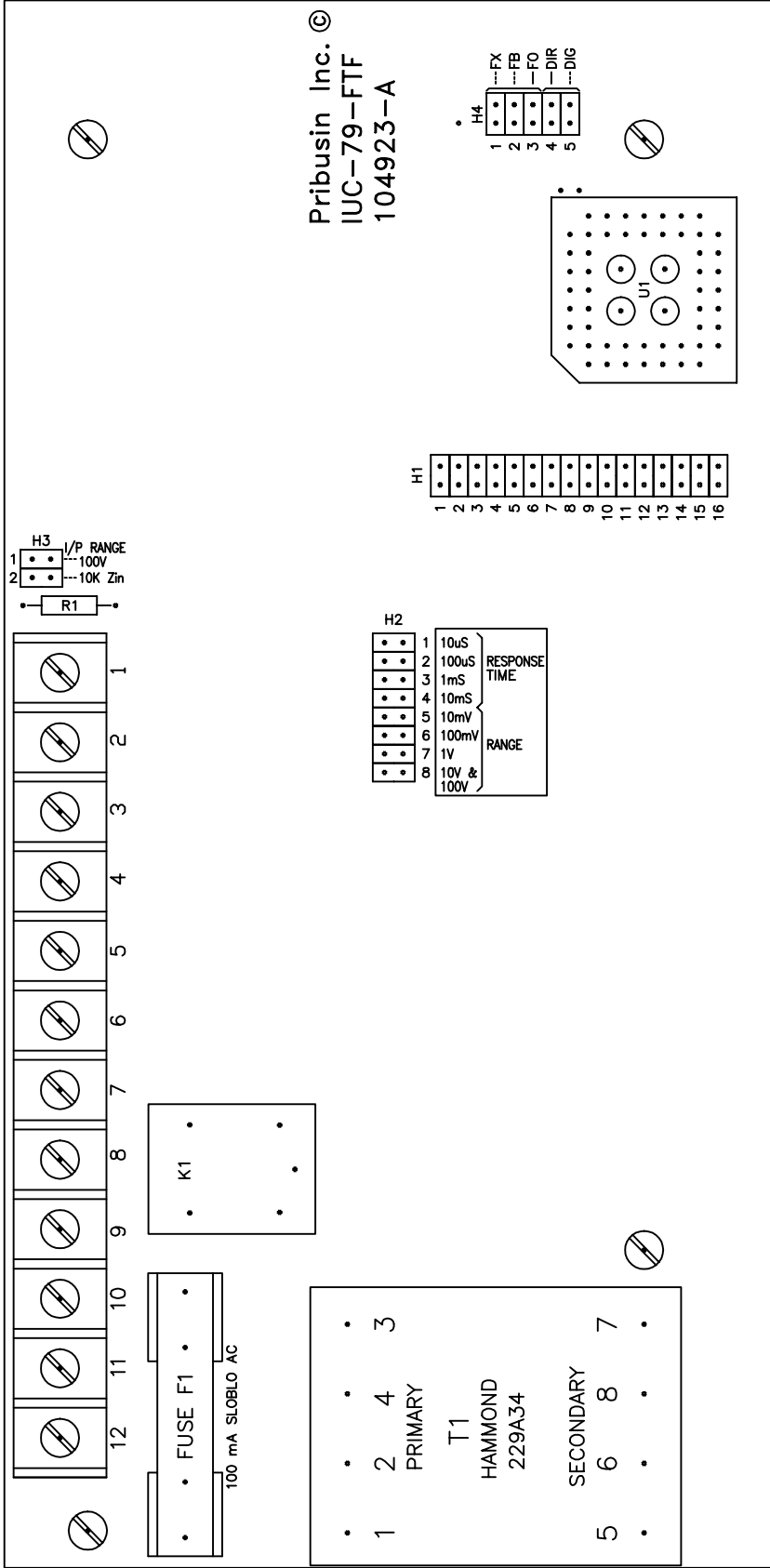

Pribusin Inc. ©  
 IUC-79-FTF  
 104923-A

<b>Pribusin Inc. ©</b>	
CHKD:	DATE: APR. 26/94
	DRN: KS
Model: IUC-79-FTF Frequency Isolator Jumper Locations	
DWG. NO.:	104924-3 Sht 3 of 3
	REV. B

# Calibration & Setup Procedure for IUC-79-FTF

(includes IUC-79-FTF-BUF & IUC-79-FTF-DIV)

## 1. Factory Settings: (unless otherwise specified at time of order)

### IUC-79-FTF:

Input Type: Voltage Input, TTL level (0-5 VDC) (jumper H2-8 inserted)  
Thresholds: ON: TP1 = 3V , OFF: TP2 = 1V  
Relay: Not installed (jumper H4-1 removed)  
Response Time: 100 microsec. (jumper H2-2 installed)  
Outputs: All 4 outputs activated (jumper H4-4 installed)

### IUC-79-FTF-BUF:

Input Type: Voltage Input, TTL level (0-5 VDC) (jumper H2-8 inserted)  
Thresholds: ON: TP1 = 3V , OFF: TP2 = 1V  
Relay: Buffered pulse output (jumper H4-2 installed)  
Response Time: 100 microsec. (jumper H2-2 installed)  
Outputs: Buffered pulse output (jumper H4-5 installed)  
Output Pulse Rate: 500 msec.

### IUC-79-FTF-DIV:

Input Type: Voltage Input, TTL level (0-5 VDC) (jumper H2-8 inserted)  
Thresholds: ON: TP1 = 3V , OFF: TP2 = 1V  
Relay: Divided Output (jumper H4-2 installed)  
Response Time: 100 microsec. (jumper H2-2 installed)  
Outputs: Divided Output (jumper H4-5 installed)  
Division Factor: 100

## 2. Input Type:

Determine the type of input that is to be applied to the IUC-79-FTF (choices are *Voltage, Dry Contact, AC or DC Coupled* ). Follow the instructions below depending on which input type you are using:

### Voltage Input:

Several input ranges for various voltage levels can be set up by jumpers H1-5 through H1-8. Select only one range and insert only one jumper for that range. *EXCEPTION:* for the 100V input range, a second jumper on H2-1 is required.

0-10 mV	insert jumper H2-5
0-100 mV	insert jumper H2-6
0-1 V	insert jumper H2-7
0-10 V	insert jumper H2-8
0-100 V	insert jumper H2-8 AND jumper H3-1

### Dry Contact Input:

Insert jumper H3-2 to select a 10 KOhm input impedance. Insert jumper H2-8 to select a 0-10 V input range. Set the ON threshold to +10 V (using TP1) and the OFF threshold to +5 V (using TP2).

### AC or DC Coupling:

The IUC-79-FTF is set up for DC Coupling by default. To change the input to AC Coupling, remove jumper J1 and replace it with a 1 uF capacitor.

### 3. Input Response Time:

There are four response times to choose from for the input conditioning circuitry. These response times help eliminate noise on the input signal. Choose a response time that is adequate for your particular frequency input. Make sure that the highest frequency that is to be accepted by the input has a period greater than the chosen response time.

10 msec	insert jumper H2-4
1 msec	insert jumper H2-3
100 microsec	insert jumper H2-2
10 microsec	insert jumper H2-1

For Example, if the maximum frequency is 2000 Hz, the period is 1/2000 sec. or 500 micro seconds. Choose either 100 micro seconds or 10 micro seconds. If you were to choose 1 msec or 10 msec, the input could not respond fast enough to your highest input frequency and the IUC-79-FTF would not accept the input.

### 4. ON & OFF Thresholds:

The IUC-79-FTF has two threshold settings: one for the ON level (rising edge of the input) and one for the OFF level (falling edge of the input). These threshold levels must be set such that the amplitude of the input signal is larger than that of the ON and OFF threshold levels. The ON and OFF LED's indicate which portion of the pulse is currently being received (on frequencies above 30 Hz, both LED's appear to be on simultaneously).

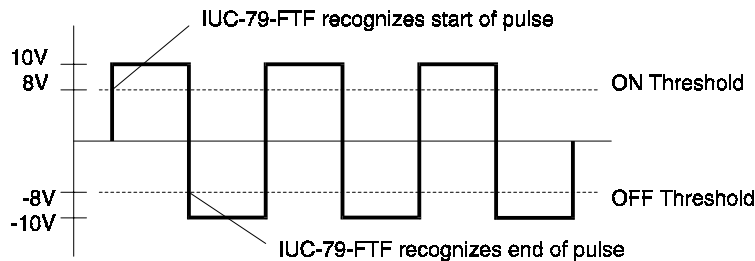

In the above example, the input signal swings from -10V to + 10V. A good threshold level is at -8V and +8V to eliminate any possible ringing noise at the rising and falling edges. For a dry contact input, choose an OFF Threshold above 0V, say 10-20% of the full scale signal.

To set the Threshold levels, use a voltmeter between TP1 and TPCOM for the ON Threshold and adjust the multiturn potentiometer until the meter reads the desired level. Do the same for the OFF Threshold using TP2 and TPCOM.

Note: If you are using an input range other than 10 V, the Threshold levels of +/- 10V represent -100% to +100% of the selected input range. For example, a threshold of 8V represents 80 mV on a 100mV input range setting.

## 5. Output Type:

The IUC-79-FTF has four standard output types. These are Open Collector, TTL (5V), 12 VDC, 24 VDC. There is also an optional relay contact output. To activate the standard outputs, jumper H4-4 must be inserted (factory default setting). To activate the relay output (if present), jumper H4-1 must be inserted. All outputs can be used simultaneously.

The 24 VDC output is a 'straight through' output which means that it follows the incoming signal directly (i.e. when the input goes high the 24 VDC output goes high, etc.). All other outputs are inverted ! (i.e. when the input goes high, the outputs go low and vice versa).

## 6. Additional Setup & Calibration for IUC-79-FTF-BUF only:

The IUC-79-FTF-BUF stores incoming pulses (frequency) in an internal buffer in its microprocessor and releases them at a slower rate as a 50% duty cycle square wave. The output pulse release rate is adjustable from immediate output (no buffering) to 6.5 second pulse durations in 0.1 msec intervals. The pulse release rate is set up using the jumper strip H1. The release time is encoded in binary which means that up to 65536 ( $2^{16}$ ) combinations of release rates are selectable. Jumper position H1-1 is equivalent to 0.1 msec, position H1-2 equals 0.2 msec, H1-3 equals 0.4 msec all the way to H1-16 which equals 3276.8 msec (3.2768 sec.).

Example: for an output pulse rate of 1/2 second (500 msec.) the jumpers on H1 have to be as follows.

H1-1 out	H1-5 out	H1-9 in	H1-13 in
H1-2 out	H1-6 out	H1-10 in	H1-14 out
H1-3 out	H1-7 out	H1-11 out	H1-15 out
H1-4 out	H1-8 in	H1-12 out	H1-16 out

The jumpers that are inserted carry the binary weights of 0.8+12.8+25.6+51.2+409.6 which when added together, results in 500.0 msec

### Output Selection:

The IUC-79-FTF-BUF can be configured as a 'straight through' instrument or a pulse buffer or a combination of both. Jumpers H4-1,2,3 control the relay output and jumpers H4-4,5 control the other 4 standard outputs. The following tables show how the different jumpers affect the operation of the outputs:

	Relay		4 Outputs
H4-1	Relay follows input directly	H4-4	Outputs follow input directly
H4-2	Relay driven by buffer	H4-5	Outputs driven by buffer
H4-3	Relay is same as other outputs (depending on H4-4,5)		

## 7. Additional Setup & Calibration for IUC-79-FTF-DIV only:

The IUC-79-FTF-DIV takes the incoming pulses (frequency) and provides a 50% duty cycle square wave output that is divided by an adjustable division factor. The division factor can be in the range of 1 to 65535 and is encoded in binary on the jumper strip H1. Position H1-1 carries the weight 1, H1-2 equals 2, H1-3 equals 4, all the way to H1-16 which equals 32768. As division by 0 is invalid, the output will stop if no division factor is set up on H1.

Example: to divide the input by 1000 the jumpers on H1 must be set as follows:

H1-1 out	H1-5 out	H1-9 in	H1-13 out
H1-2 out	H1-6 in	H1-10 in	H1-14 out
H1-3 out	H1-7 in	H1-11 out	H1-15 out
H1-4 in	H1-8 in	H1-12 out	H1-16 out

The jumpers that are inserted carry the binary weights of  $8+32+64+128+256+512$  which when added together, results in 1000.

### Output Selection:

The IUC-79-FTF-DIV can be configured as a 'straight through' instrument or a divider or a combination of both. Jumpers H4-1,2,3 control the relay output and jumpers H4-4,5 control the other 4 standard outputs. The following tables show how the different jumpers affect the operation of the outputs:

	Relay		4 Outputs
H4-1	Relay follows input directly	H4-4	Outputs follow input directly
H4-2	Relay driven by divider	H4-5	Outputs driven by divider
H4-3	Relay is same as other outputs (depending on H4-4,5)		