



*Manufacturers of Process  
Controls and Instrumentation*

# ***Instruction Manual***

Model: *MTS-XXX*

Function: *Modular Telemetry System*

- Module:
- XXX=8DI: 8-Channel Digital Input*
  - XXX=8DO: 8-Channel Digital Output*
  - XXX=4AI: 4-Channal Analog Input*
  - XXX=4AO: 4-Channel Analog Output*
  - XXX=PWR: Power Distribution*
  - XXX=RAD: Radio Communication*
  - XXX=4DIO: 4-Channel Digital Input & Output*

Output:  (4) 4-20mA

\_\_\_\_\_

Serial #: \_\_\_\_\_

(If special or required)

For Technical Assistance And Questions Call  
USA: (231) 788-2900 CANADA: (905) 660-5336

## Restocking Policy

**All product returned to Pribusin Inc. in prime condition (not damaged, scratched or defaced in any way) within seven (7) months from the original date of shipment is subject to a 50% restocking charge. All product must be accompanied by a Return Authorization number (RA number) which must be obtained from Pribusin Inc. prior to returning any product.**

**After seven (7) months from the original date of shipment, products cannot be returned for restocking.**

**Custom designed products, modified products or all non-standard products may not be returned for restocking.**

## Warranty Policy

**Pribusin Inc. warrants equipment of its own manufacture to be free from defects in material and workmanship, under normal conditions of use and service, and will replace any component found to be defective, on its return to Pribusin Inc., transportation charges prepaid, within one year of its original purchase. Pribusin Inc. will extend the same warranty protection on equipment, peripherals and accessories which is extended to Pribusin Inc. by the original manufacturer. Pribusin Inc. also assumes noliability, expressed or implied, beyond its obligation to prelace any component involved. Such warranty is in lieu of all other warranties, expressed or implied.**

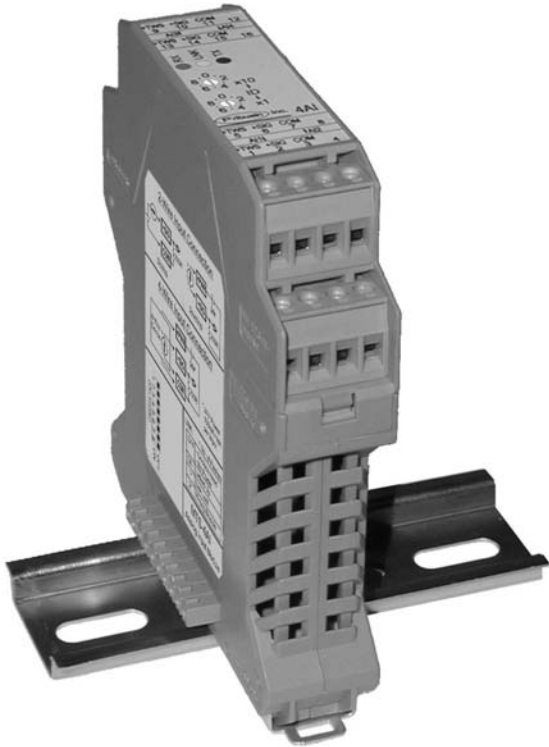

### Function:

The MTS-4AO is a 4 channel analog output module. It provides analog output capability for an MTS series telemetry system. The MTS-4AO communicates with its counterpart, the MTS-4AI analog input module.

Outputs are isolated from each other to provide added protection and to prevent ground loops. Output resolution is 16-bits for high accuracy.

Outputs can be wired to be sinking or sourcing depending on the 4-20mA signal source.

Deployment and installation is as simple as plugging the needed I/O modules into the communications module and assigning unique module ID's. Power and communication for the modules are provided through an integral bus.

### Standard Features:

4 Analog Outputs (4-20mA)

Outputs are Isolated to 1.5kV

24V Power Supply Output for Sourcing 4-20mA

Integrated Power & Data Bus Reduces Wiring

Modular Design Provides Maximum Flexibility

No Programming Required - Easy to Configure

Microprocessor Controlled for High Accuracy

Power: 24 VDC (From Integrated Bus)

Easy Future Expansion

### Configuration:

The MTS-4AO output module must be paired up with the MTS-4AI input module. Both modules must be set to the same ID with the ID Selector Switches. Each output can be wired as either sinking or sourcing type.

### Specifications:

Outputs: 4-20mA sinking

4-20mA sourcing (max. 20mA)

Power Consumption: 0.5VA min., 2.5VA max.

Isolation: 1.5kV, Optically Isolated

# MTS-4AO

## Module Dimensions:

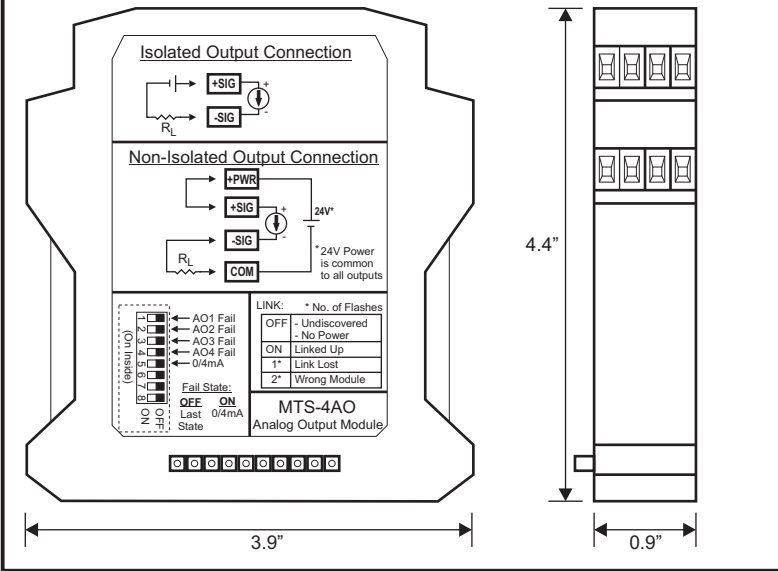

## Top View:

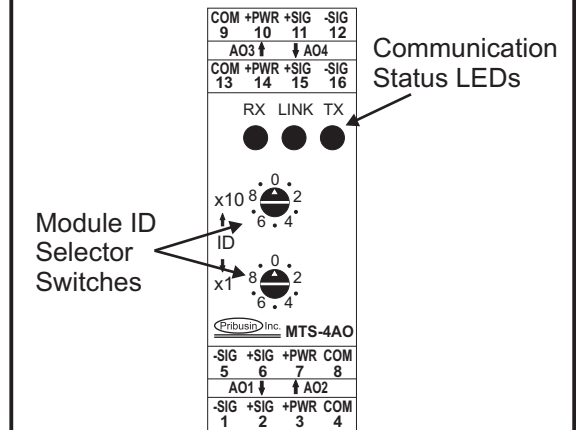

## System Example:

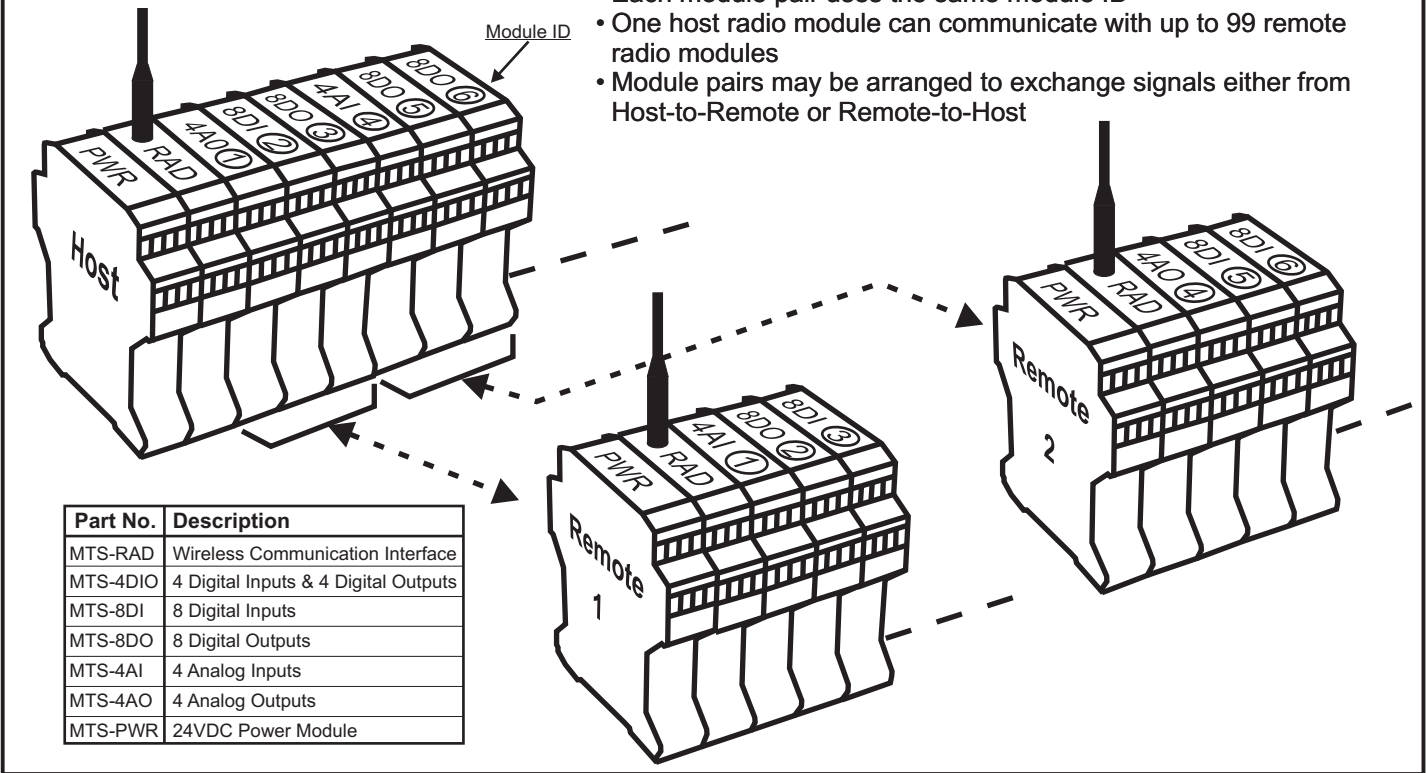

## Manufactured By:

**Pribusin Inc.**

www.pribusin.com  
 info@pribusin.com

### USA:

Pribusin Inc.  
 743 Marquette Ave.  
 Muskegon, MI 49442  
 Ph: (231) 788-2900  
 Fx: (231) 788-2929



### CANADA:

Pribusin Inc.  
 101 Freshway Dr. Unit 57  
 Concord, Ontario, L4K 1R9  
 Ph: (905) 660-5336  
 Fx: (905) 660-4068

## **MTS-4AO Functional Description:**

The MTS-4AO is a 4-channel analog output module. It has 4 isolated 4-20mA outputs that are controlled by the 4 inputs from its counterpart module, the MTS-4AI analog input module. The modules communicate via an MTS communications module. Both input and output modules must be set to the same module ID to allow them to communicate.

There are 4 outputs on the MTS-4AO. They can be wired in either an isolated or non-isolated fashion. Power and communication signal connections are achieved via the integral connector at the bottom of the module. Assembling a stack of several MTS modules on a DIN Rail and sliding them together is all that is required to interconnect I/O modules with a communications or power module.

### **Output Types:**

Each of the 4 outputs is an isolated 4-20mA current output. It can be wired to be an isolated, sinking-type output or a non-isolated sourcing-type output

Isolated Sinking Output: Each output of the MTS-4AO can be used as a sinking-type 4-20mA output. An externally powered loop will be modulated to 4-20mA by the output in correspondence with the input of an MTS-4AI.

Non-Isolated Sourcing Output: If a sourcing output is required, each input can be powered from the internal 24VDC supply. Since the 24VDC power is not isolated, this action ties the output to the MTS stack power supply and nullifies the isolation.

### **Output Fail Status:**

In the event of a communications failure between the MTS-4AO and its counterpart MTS-4AI module, each of the 4 analog outputs can be configured to either remain in its last state or be forced to 0mA or 4mA.

# MTS-4AO Installation:

## Physical Mounting:

The MTS-4AO module easily snaps onto standard 35mm top-hat style DIN rail for mounting. Each module has a 10-position interconnect bus near the base that provides power and inter-module communication. Once modules are snapped onto the DIN rail they simply slide together and connect via their integrated interconnect bus. See figure 1 below for an illustration.

To remove a module, slide it off the end of the DIN rail or insert a screwdriver into the slot of the retaining clamp at the base of the module and push the screwdriver towards the module – now lift it out.

**WHEN ASSEMBLING A STACK OF MODULES OR ADDING OR REMOVING A MODULE MAKE SURE POWER TO THE WHOLE STACK IS OFF.**

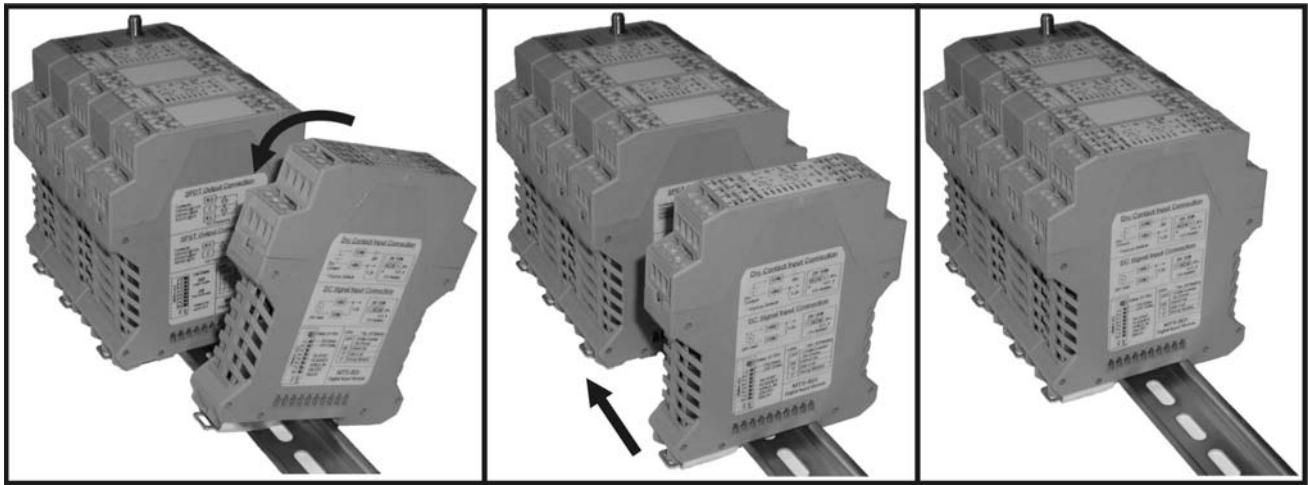

Figure 1

## Signal Wiring:

To facilitate easy installation, all terminals are plug-in style and can be removed for wiring purposes. Figure 2 shows the arrangement of the various outputs.

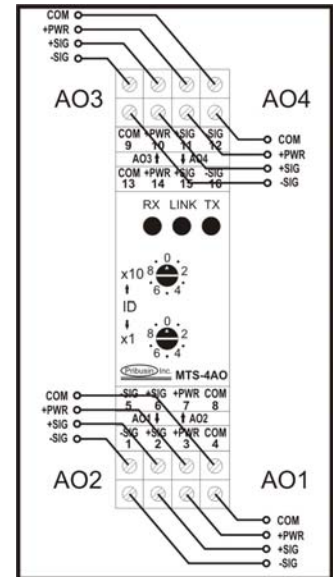

Figure 2

**Signal Wiring (cont'd):**

Figure 3a shows the typical output wiring for an isolated output connection. The output is a sinking-type output and the power for the 4-20mA loop is provided by an external (isolated) power supply.

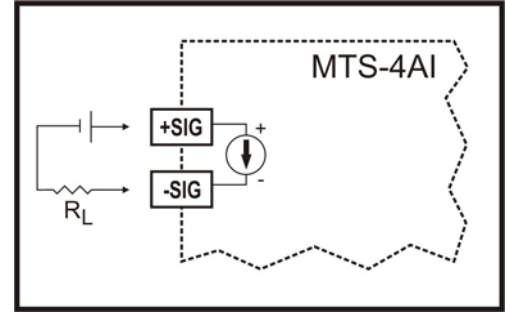

Figure 3a

Figure 3b shows the typical output wiring for a non-isolated output connection. The output is a sinking-type output but is powered from the internal 24V supply to become a sourcing-type output.

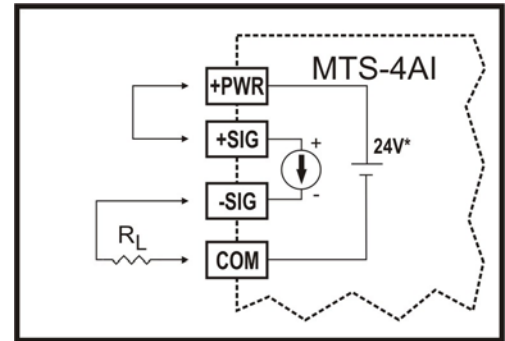

Figure 3b

## **MTS-4AO Configuration:**

To configure some functions of the MTS-4AO it may be necessary to remove the circuit board and cover assembly from the enclosure body. When doing so, make sure that you adequately protect yourself against static electricity buildup by wearing proper grounding straps.

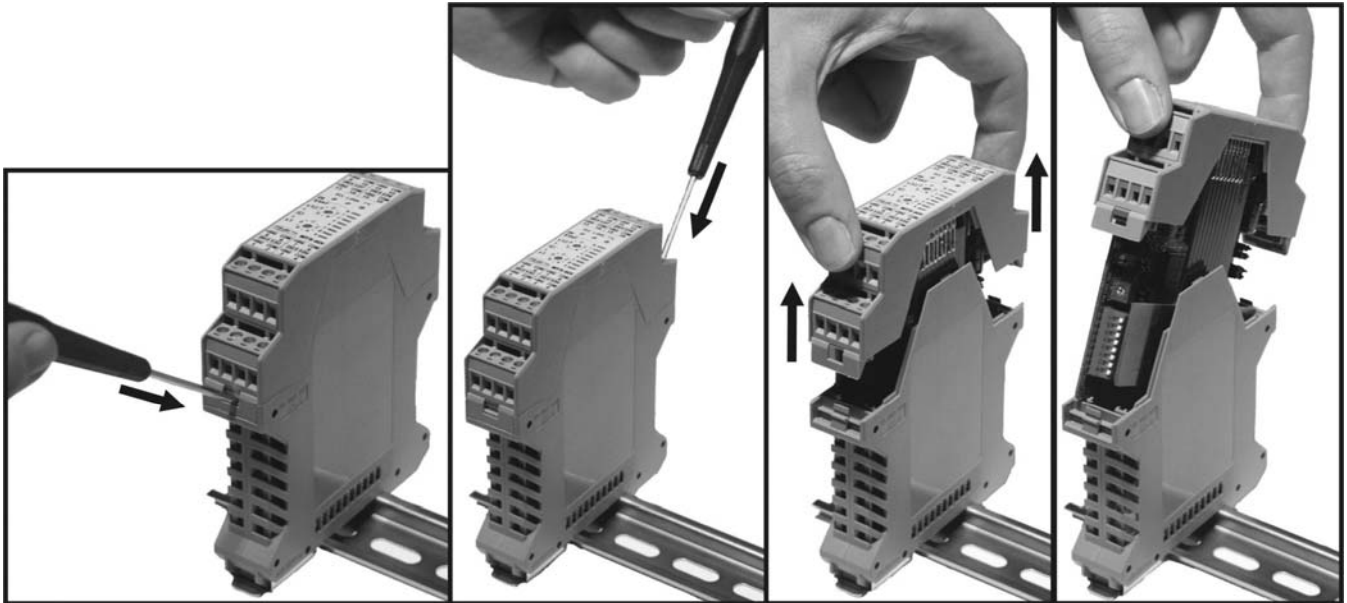











Figure 4

Figure 4 shows how to open the MTS enclosure. ***Before proceeding, make sure all power is turned off to the MTS stack.*** Using a small screwdriver, push in the two locking tabs on either side of the MTS just below the lower terminal plug. This unlocks the cover. Gently pull on the cover away from the enclosure body until the circuit board is free of the enclosure. Make the necessary adjustments and replace the cover and board assembly in the same orientation as it was removed. Be sure not to accidentally rotate the assembly by 180° when re-inserting it into the enclosure body. When inserting the lower end of the circuit board(s), make sure the board(s) slides into the guide-rails on the inside of the enclosure. Gently push on the top cover until it is firmly seated and the locking tabs click in place.

## Output Fail Configuration:

In the event of a communications failure between the MTS-4AO and its counterpart MTS-4AI module, each of the 4 analog outputs can be configured to either remain in its last state or be forced into either a 0mA or 4mA output level. The first 4 DIP switches (SW1..SW4) each controls the fail status of one analog output (AO1..AO4). With a DIP switch in the UP position the corresponding output will remain at its last state indefinitely until communications is restored or the power to the module is interrupted. With a DIP switch in the DOWN position the corresponding output will be forced to either 0mA (SW5 DOWN) or 4mA (SW5 UP, default)

Output Fail Level	SW5	
4mA	UP	
0mA	DOWN	

Output	SWx	Fail State	
Output #1 (SW1)	UP	Last Level	
	DOWN	See SW5	
Output #2 (SW2)	UP	Last Level	
	DOWN	See SW5	
Output #3 (SW3)	UP	Last Level	
	DOWN	See SW5	
Output #4 (SW4)	UP	Last Level	
	DOWN	See SW5	

## Module ID:

An MTS system consists of at least two 'stacks' of modules – one host stack and one or more remote stacks. Each stack consists of a communications module and one or more I/O modules. Each I/O module must be assigned a Module ID before it will be recognized in a stack. Module ID's allow multiple I/O modules to share the common communications module.

MTS modules always operate in pairs - one input module is paired up with one output module. These two modules are assigned the same Module ID so that they can communicate with one another from one stack to the other. These two modules are also the *only two* modules in an MTS system that have that particular Module ID. One module is part of the host stack and the other module is part of a remote stack.

Module ID's in a stack of MTS modules do not have to be consecutive but must be unique – there cannot be two modules with the same Module ID in one stack. Module ID's range from 1-99 and are set using the two rotary switches on the top of each I/O module. One switch is for the 1's digit and the other for the 10's digit of the Module ID. Figure 6 shows some examples of Module ID's.

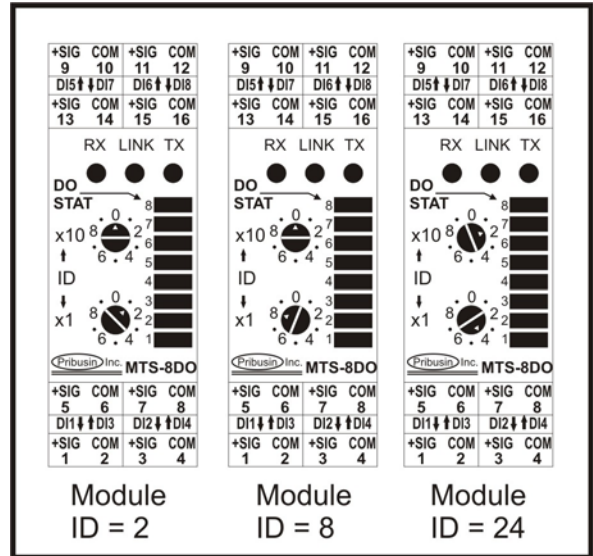

Figure 6

Figure 7 shows a typical MTS system consisting of one Host Stack and two Remote Stacks.

Module ID's in a system do not have to be consecutive (Module ID's 4 & 5 are not present).

Only two modules can have the same Module ID: one of them is an input module, the other is an output module. Input and output modules may be located on either the Host or Remote stacks depending on which way the signal is intended to be sent.

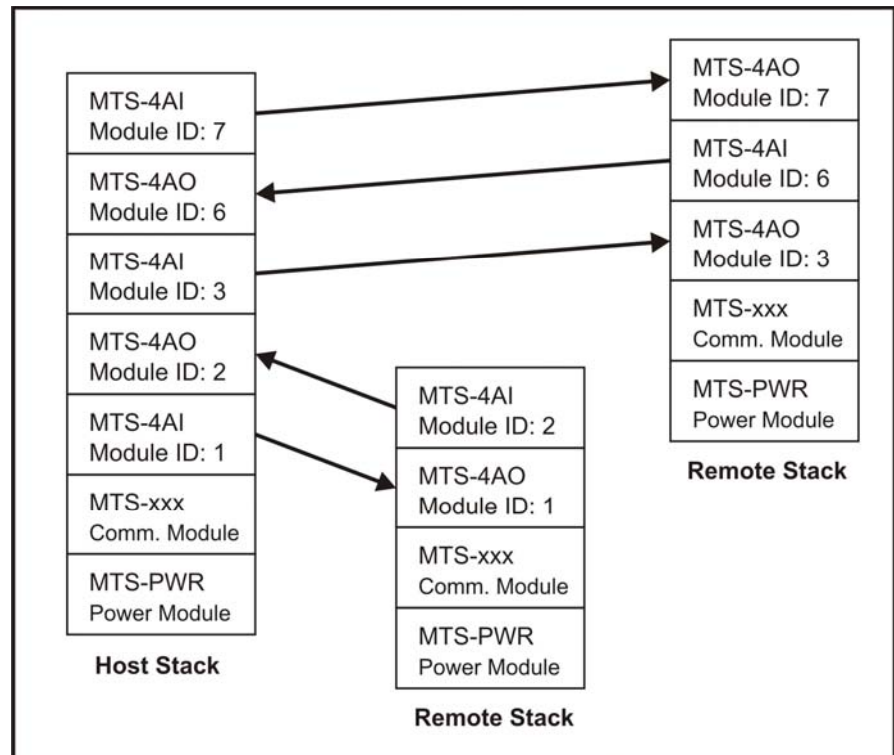

Figure 7

## MTS-4AO Operation:

When an MTS system is first powered on, there is a brief time of inactivity (approx. 30 seconds) while the Communication Modules discover which I/O modules are present in their stack. After the discovery period is over, the modules on the Host Stack will begin communicating with their counter part modules on a Remote Stack. Communication occurs one module at a time and in numerical order for all Module ID's present on the Host Stack. A careful observer can witness this by the TX (transmit) and RX (receive) lights on each module.

### Link Status Light:

Once two modules have communicated for the first time, they illuminate their Link lights to indicate that the modules have found each other and that a successful data exchange has taken place. This Link light will remain in a solid on state while communication between the two modules continues to be successful.

The Link light will flash when there is a problem with the communication between the two modules. Several flashing sequences indicate the nature of the problem.

Link Status	Description
Off	Undiscovered or No Power
On	Linked with other Module
1 Flash	Link with other Module Lost
2 Flashes	Linked with Wrong Module Type

A **single flash** indicates that the module has lost communication with its counterpart module. Reasons for this include, but are not limited to:

Problem	Check
'Other Stack' lost Power	<ul style="list-style-type: none"> <li>Verify power on 'Other Stack'</li> <li>Check other Modules - Not likely if another Module from the 'Other Stack' is still communicating with a Module from 'This Stack'</li> </ul>
Communication Module Bad on 'This Stack'	<ul style="list-style-type: none"> <li>Check other Modules on 'This Stack' – Not Likely if any are still linked and communicating</li> </ul>
Bad counter-part I/O Module on 'Other Stack'	<ul style="list-style-type: none"> <li>Check TX/RX Lights on Module on 'Other Stack'</li> </ul>
Bad I/O Module on 'This Stack'	<ul style="list-style-type: none"> <li>Check TX/RX Lights on Module on 'This Stack'</li> </ul>

The above table describes some scenarios that could result in lost communication. For further assistance please contact your local representative or Pribusin Inc.

A **double flash** indicates that the module is trying to communicate with a counter-part module that is not the correct input or output type. Examples of this are: 1) an analog module tries to communicate with a digital module or 2) an input module tries to communicate with another input module. This is most likely the result of improperly assigned Module ID's. Check all Module ID's carefully and make sure that modules with the same ID are the correct pair (one input and one output) and that they are of the same type (both digital or analog, but not mixed).

# MTS System Overview:

This section describes the concept and operation of a typical MTS system. The example below uses two remote sites, labeled 'Remote 1' and 'Remote 2'. Following are important points to note when designing or installing an MTS system:

- Every MTS system has one Host Stack and one or more Remote Stacks
- Each stack consists of at least one power module (MTS-PWR), one communications module (MTS-xxx, see table below for xxx), and one or more I/O modules
- I/O modules are always paired (one input module and one output module)
- One module of each pair (either input module or output module) **MUST** be on the Host Stack
- Each module pair **MUST** use the same Module ID
- Modules may be arranged to send their signals from Host-to-Remote or Remote-to-Host depending on which stack the input and output modules are located

Figure 8 shows a typical two remote system with a mixture of I/O modules arranged in ways so that some modules send signals from the Host Stack to the Remote Stacks while other modules send signals from a Remote Stack back to the Host Stack.

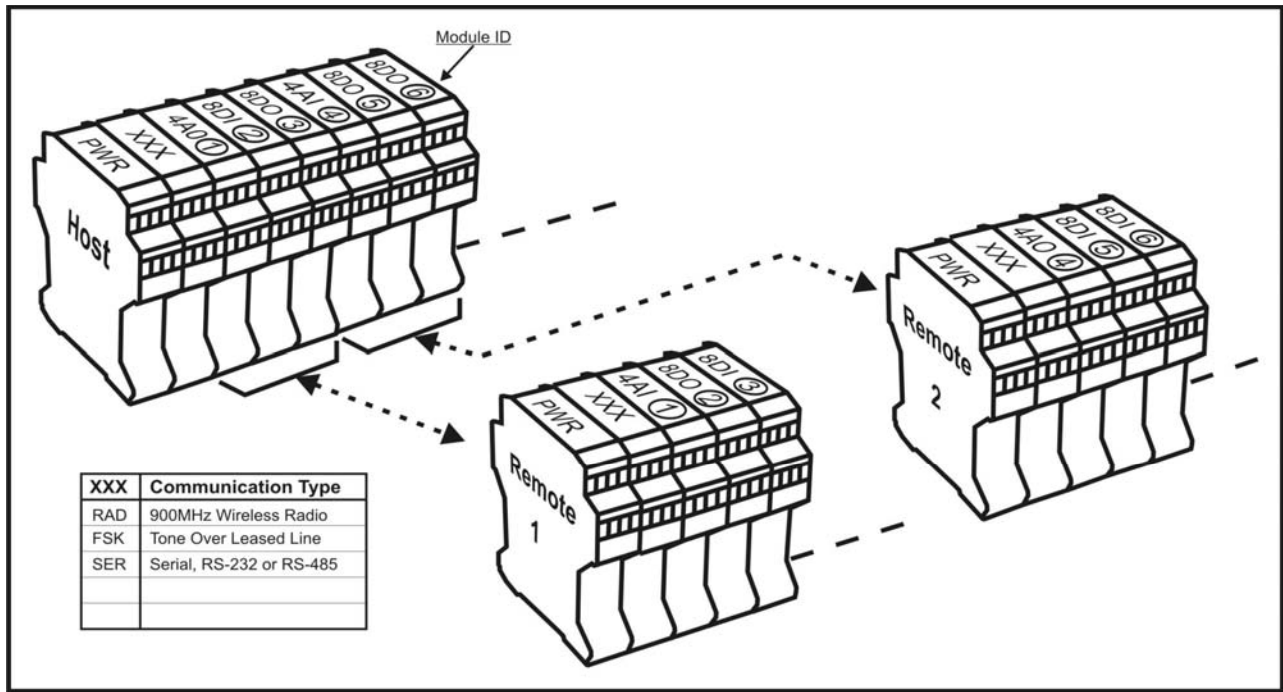

Figure 8

This table shows the modules that are currently available. Check our website at [www.pribusin.com](http://www.pribusin.com) or with your local representative for the latest list of available modules.

Model No.	Description
MTS-RAD	900MHz Wireless Comm. Module
MTS-8DI	8 Channel Digital Input Module
MTS-8DO	8 Channel Digital Output Module
MTS-4AI	4 Channel Analog Input Module
MTS-4AO	4 Channel Analog Output Module
MTS-PWR	24VDC Power Module