



*Manufacturers of Process
Controls and Instrumentation*

Instruction Manual

Model: *MTS-XXX*

Function: *Modular Telemetry System*

- Module:
- XXX=8DI: 8-Channel Digital Input*
 - XXX=8DO: 8-Channel Digital Output*
 - XXX=4AI: 4-Channal Analog Input*
 - XXX=4AO: 4-Channel Analog Output*
 - XXX=PWR: Power Distribution*
 - XXX=RAD: Radio Communication*
 - XXX=4DIO: 4-Channel Digital Input & Output*

Output: (8) Relay Contacts

Serial #: _____

(If special or required)

For Technical Assistance And Questions Call
USA: (231) 788-2900 CANADA: (905) 660-5336

WARNING

THIS INSTRUCTION MANUAL MUST BE CAREFULLY READ BY ALL INDIVIDUALS WHO HAVE OR WILL HAVE THE RESPONSIBILITY FOR INSTALLING, USING OR SERVICING THIS PRODUCT. LIKE ANY PIECE OF COMPLEX EQUIPMENT, THIS PRODUCT WILL PERFORM AS DESIGNED ONLY IF INSTALLED, USED AND SERVICED IN ACCORDANCE WITH THE MANUFACTURER'S INSTRUCTIONS. OTHERWISE, IT COULD FAIL TO PERFORM AS DESIGNED AND PERSONS WHO RELY ON THIS PRODUCT FOR THEIR SAFETY COULD SUSTAIN SEVERE PERSONAL INJURY OR DEATH.

The warranties made by Pribusin Inc. with respect to these products are voided if the products are not installed, used and serviced in accordance with the instructions in this instruction manual. Please protect yourself and others by following them.

General Warnings and Cautions

- This apparatus is suitable for use in Class I, Division 2 Groups A, B, C & D
- **WARNING: EXPOSURE TO SOME CHEMICALS MAY DEGRADE THE SEALING PROPERTIES OF MATERIALS USED IN THE FOLLOWING DEVICES:**
 - Relay (MTS-8DO only): AROMAT (NAIS), JQ1-24V & JS1-24V (Inspect relays periodically to ensure that no degradation is found)
- **WARNING: EXPLOSION HAZARD. DO NOT REMOVE OR REPLACE LAMPS, FUSES OR PLUG-IN MODULES UNLESS POWER HAS BEEN DISCONNECTED OR THE AREA IS KNOWN TO BE FREE OF IGNITABLE CONCENTRATIONS OF FLAMMABLE GASES OR VAPORS.**
- **WARNING: EXPLOSION HAZARD. SUBSTITUTION OF COMPONENTS MAY IMPAIR SUITABILITY FOR CLASS I, DIVISION 2.**
- **WARNING: EXPLOSION HAZARD. DO NOT DISCONNECT WHILE CIRCUIT IS LIVE UNLESS AREA IS KNOWN TO BE NON-HAZARDOUS.**
- **AVERTISSEMENT: RISQUE D'EXPLOSION. NE PAS DEBRANCHER TANT QUE LE CIRCUIT EST SOUS TENSION, A MOINS QU'IL NE S'AGISSE D'UN EMPLACEMENT NON DANGEREUX.**
- **AVERTISSEMENT: RISQUE D'EXPLOSION. LA SUBSTITUTION DE COMPOSANTS PEUT RENDRE CE MATERIEL INACCEPTABLE POUR LES EMPLACEMENTS DE CLASSE 1, DIVISION 2.**

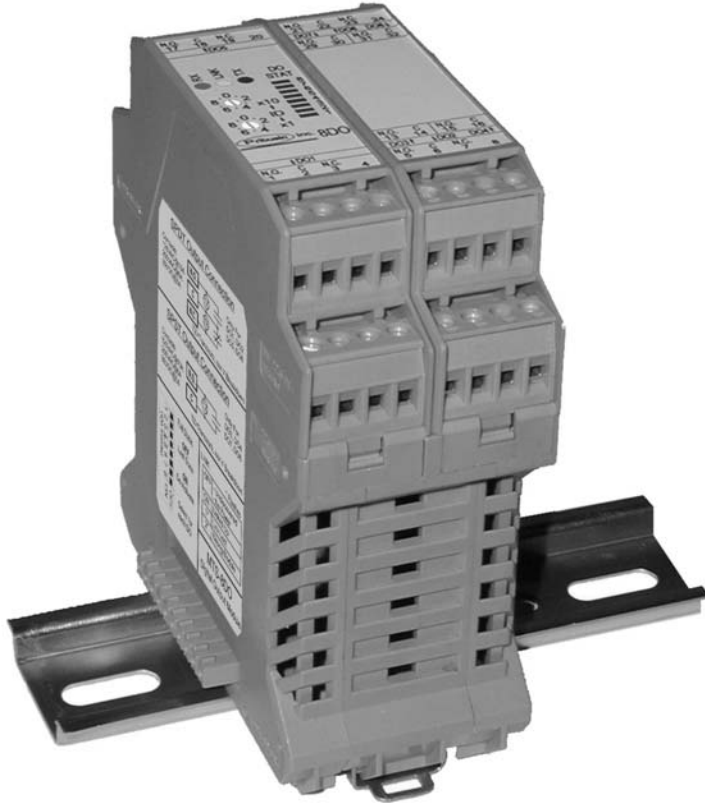

Function:

The MTS-8DO is an 8 channel digital output module. It provides digital output capability for an MTS series telemetry system. The MTS-8DO communicates with its counterpart, the MTS-8DI digital input module.

2 outputs are SPDT (form 'C') outputs with one Normally-Open and one Normally Closed connection, while the remaining 6 outputs are SPST (form 'A') outputs with a Normally Open connection. The output status of each channel is indicated individually.

Deployment and installation is as simple as plugging the needed I/O modules into the communications module and assigning unique module ID's. Power and communication for the modules are provided through an integral bus.

Optional power supply modules add battery backup and solar power capability.

Standard Features:

- 8 Digital Outputs (Relay Contacts)
- Form 'C' Contacts (2) and Form 'A' Contacts (6)
- Output Status Indication
- Selectable Fault Condition State
- Integrated Power & Data Bus Reduces Wiring
- Modular Design Provides Maximum Flexibility
- No Programming Required - Easy to Configure
- Microprocessor Controlled for High Accuracy
- Power: 24 VDC (From Integrated Bus)
- Easy Future Expansion

Configuration:

The MTS-8DO output module must be paired up with the MTS-8DI input module. Both modules must be set to the same ID with the ID Selector Switches. Each output can be configured to remain in its last state or deactivate during a communications fail condition.

Specifications:

- Outputs: 6 SPST & 2 SPDT Relay Contacts
- Contact Rating: 125VAC @ 3A
250VAC @ 1A
30VDC @ 3A
- Contact Arc Suppression: Yes (MOV)
- Power Consumption: 0.5VA (All Outputs Open)
2.5VA (All Outputs Closed)

MTS-8DO

Module Dimensions:

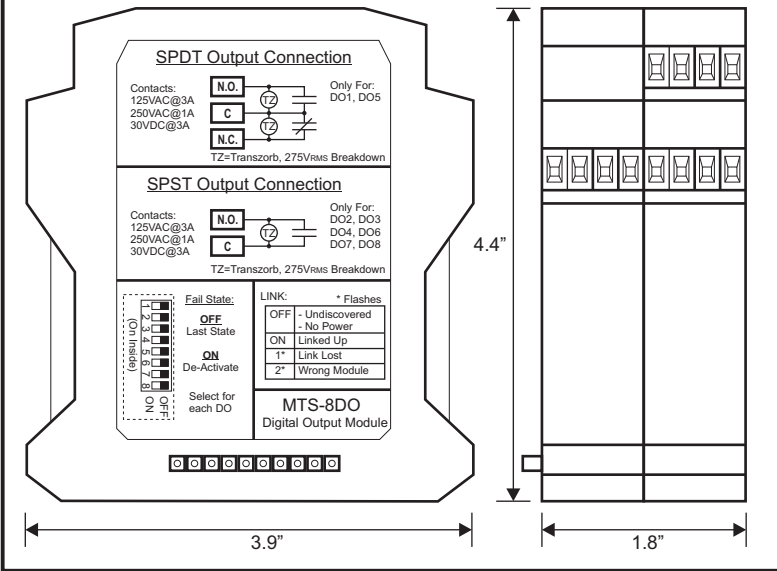

Top View:

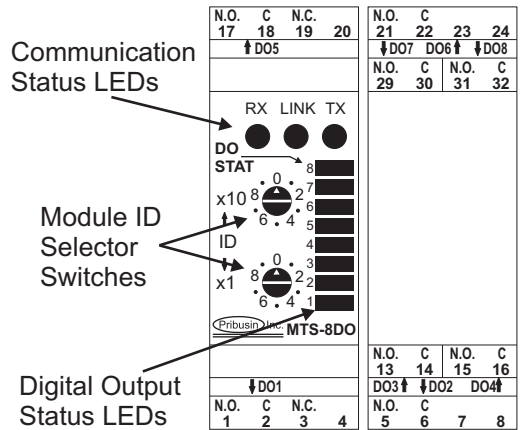

System Example:

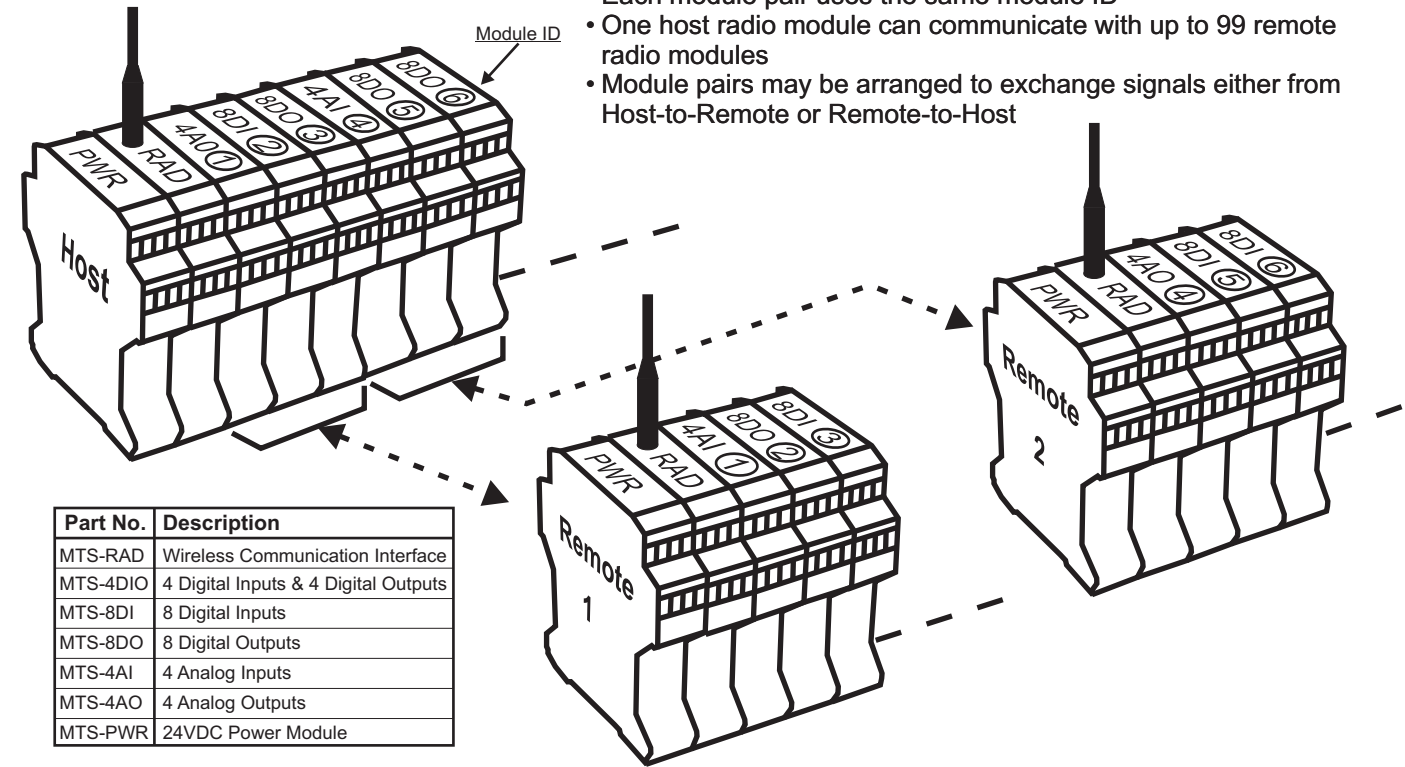

Manufactured By:



www.pribusin.com
 info@pribusin.com

USA:

Pribusin Inc.
 743 Marquette Ave.
 Muskegon, MI 49442
 Ph: (231) 788-2900
 Fx: (231) 788-2929



CANADA:

Pribusin Inc.
 101 Freshway Dr. Unit 57
 Concord, Ontario, L4K 1R9
 Ph: (905) 660-5336
 Fx: (905) 660-4068

MTS-8DO Functional Description:

The MTS-8DO is an 8-channel digital output module. It has 8 relay contact outputs that are activated by the 8 inputs from its counterpart module, the MTS-8DI digital input module. The modules communicate via an MTS communications module. Both input and output modules must be set to the same module ID to allow them to communicate.

There are 8 relay outputs on the MTS-8DO: 2 'C' Contacts (SPDT, normally-open and normally-closed) and 6 'A' Contacts (SPST, normally-open). Power and communication signal connections are achieved via the integral connector at the bottom of the module. Assembling a stack of several MTS modules on a DIN Rail and sliding them together is all that is required to interconnect I/O modules with a communications or power module.

Output Contacts:

Each of the 8 outputs is a separate relay with either SPDT or SPST contacts. All relays are normally de-energized and become energized when the corresponding input on the MTS-8DI module closes.

SPDT Contact Outputs (one normally-open *and* one normally closed): DO1 & DO5.

SPST Contact Outputs (one normally-open *only*): DO2, DO3, DO4, DO6, DO7 & DO8.

Output Indication:

Each of the 8 outputs has its own status indicator. If the output is off and the relay is de-energized the indicator for that output is off. If the output is on and the relay is energized the indicator for that output is on.

Output Fail Status:

In the event of a communications failure between the MTS-8DO and its counterpart MTS-8DI module, each of the 8 relay outputs can be configured to either remain in its last state or be forced into its de-energized state.

Input Delay (Hysteresis):

The outputs of the MTS-8DO may be delayed by a hysteresis setting on the MTS-8DI module. The MTS-8DI has selectable hysteresis settings for both ON (input closing) and OFF (input opening). If hysteresis is active on the MTS-8DI, the outputs on the MTS-8DO will not change state until the hysteresis delay on the MTS-8DI has expired. See MTS-8DI Manual for more details on hysteresis configuration.

MTS-8DO Installation:

Physical Mounting:

The MTS-8DO module easily snaps onto standard 35mm top-hat style DIN rail for mounting. Each module has a 10-position interconnect bus near the base that provides power and inter-module communication. Once modules are snapped onto the DIN rail they simply slide together and connect via their integrated interconnect bus. See figure 1 below for an illustration.

To remove a module, slide it off the end of the DIN rail or insert a screwdriver into the slot of the retaining clamp at the base of the module and push the screwdriver towards the module – now lift it out.

WHEN ASSEMBLING A STACK OF MODULES OR ADDING OR REMOVING A MODULE MAKE SURE POWER TO THE WHOLE STACK IS OFF.

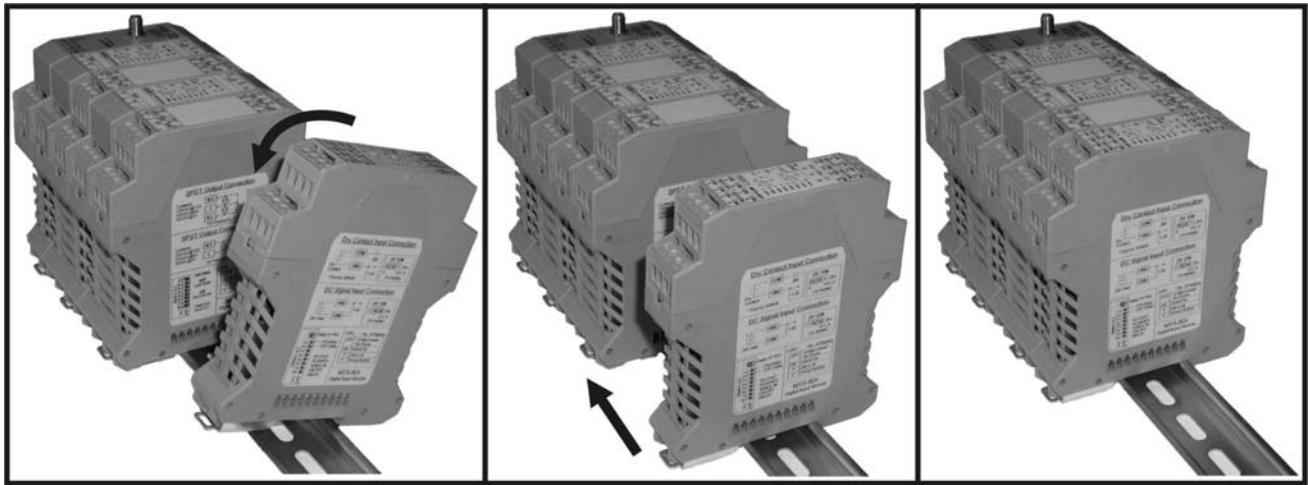

Figure 1

Signal Wiring:

To facilitate easy installation, all terminals are plug-in style and can be removed for wiring purposes. Figure 2 shows the arrangement of the various outputs.

WARNING: MORE THAN ONE LIVE CIRCUIT – SEE DIAGRAM.

AVERTISSEMENT: PLUS QU'UN CIRCUIT SOUS TENSION – VOIR LE DIAGRAM

WARNING: EXPLOSION HAZARD. DO NOT DISCONNECT WHILE CIRCUIT IS LIVE OR UNLESS THE ARE IS KNOW TO BE FREE OF IGNITIBLE CONCENTRATIONS OF FLAMMABLE GASES OR VAPORS.

AVERTISSEMENT: RISQUE D'EXPLOSION. NE PAS DEBRANCHER TANT QUE LE CIRCUIT EST SOUS TENSION, A MOINS QU'IL NE S'AGISEE D'UN EMPLACEMENT NON DANGEREUX.

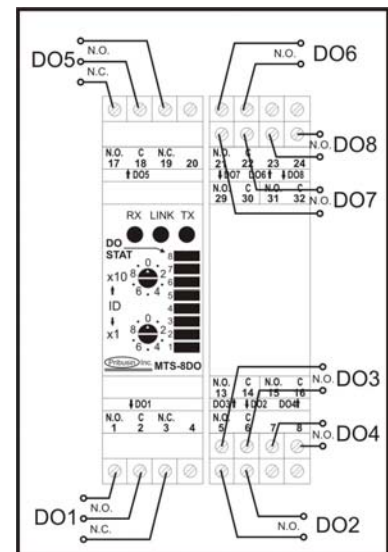

Figure 2

Signal Wiring (cont'd):

Figure 3a shows the typical output wiring for an SPDT Output (DO1, DO2, DO5 & DO6). Each output has one normally-opened (N.O.) and one normally closed (N.C.) relay contact that share one common (COM) return line.

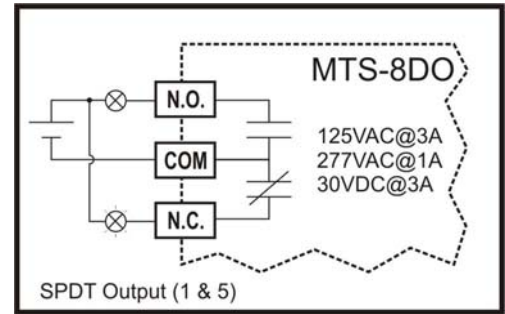

Figure 3a

Figure 3b shows the typical output wiring for an SPST Output (DO3, DO4, DO7 & DO8). Each output has one normally-opened (N.O.) relay contact and one common (COM) return line.

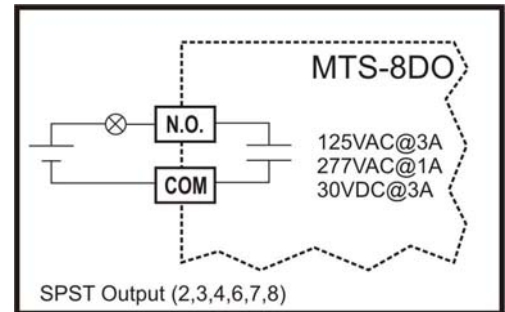

Figure 3b

MTS-8DO Configuration:

To configure some functions of the MTS-8DO it may be necessary to remove the circuit board and cover assembly from the enclosure body. When doing so, make sure that you adequately protect yourself against static electricity buildup by wearing proper grounding straps.

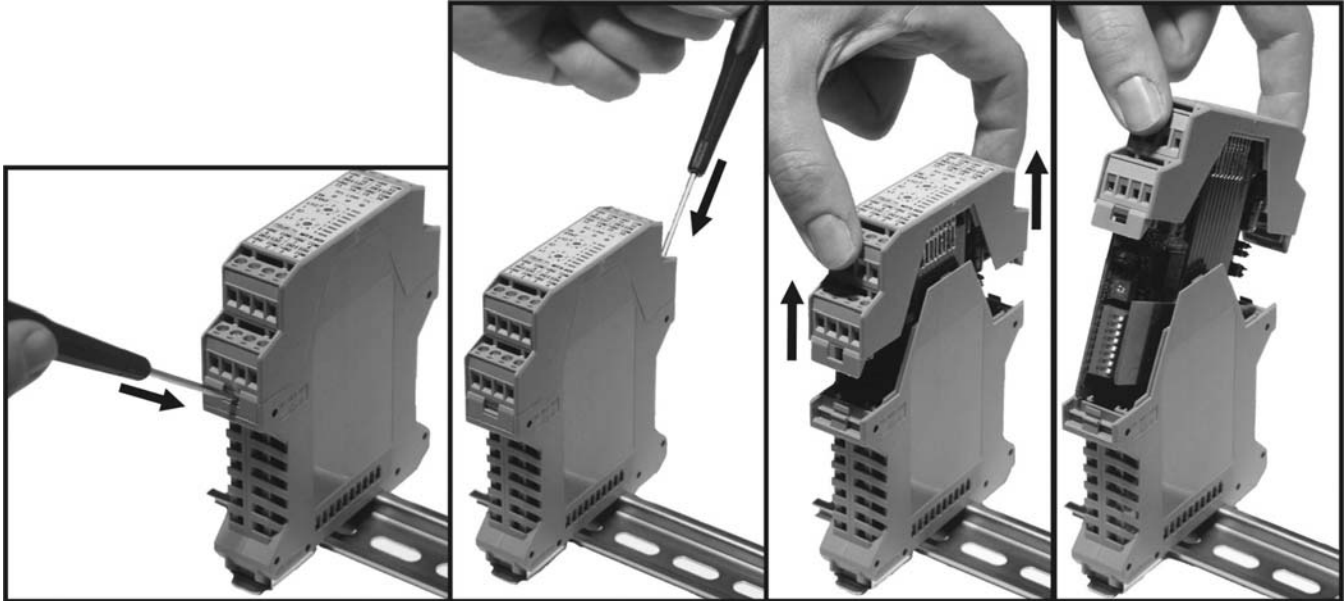

Figure 4

Figure 4 shows how to open the MTS enclosure. **Before proceeding, make sure all power is turned off to the MTS stack.** Using a small screwdriver, push in the two locking tabs on either side of the MTS just below the lower terminal plug. This unlocks the cover. Gently pull on the cover away from the enclosure body until the circuit board is free of the enclosure. Make the necessary adjustments and replace the cover and board assembly in the same orientation as it was removed. Be sure not to accidentally rotate the assembly by 180° when re-inserting it into the enclosure body. When inserting the lower end of the circuit board(s), make sure the board(s) slides into the guide-rails on the inside of the enclosure. Gently push on the top cover until it is firmly seated and the locking tabs click in place.

Output Fail State Configuration:

In the event of a communications failure between the MTS-8DO and its counterpart MTS-8DI module, each of the 8 relay outputs can be configured to either remain in its last state or be forced into its de-energized state. Each of the 8 DIP switches (SW1..SW8) controls the fail status of one output relay (DO1..DO8). With a DIP switch in the UP position the corresponding relay will remain at its last state indefinitely until communications is restored or the power to the module is interrupted.

With a DIP switch in the DOWN position the corresponding relay will be forced to the de-energized state until communications is restored.

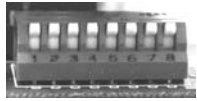
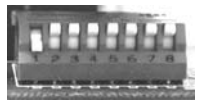
Output Fail State	SWx (x=1..8)	
Last State	UP	
De-Energize	DOWN	

Module ID:

An MTS system consists of at least two 'stacks' of modules – one host stack and one or more remote stacks. Each stack consists of a communications module and one or more I/O modules. Each I/O module must be assigned a Module ID before it will be recognized in a stack. Module ID's allow multiple I/O modules to share the common communications module.

MTS modules always operate in pairs - one input module is paired up with one output module. These two modules are assigned the same Module ID so that they can communicate with one another from one stack to the other. These two modules are also the *only two* modules in an MTS system that have that particular Module ID. One module is part of the host stack and the other module is part of a remote stack.

Module ID's in a stack of MTS modules do not have to be consecutive but must be unique – there cannot be two modules with the same Module ID in one stack. Module ID's range from 1-99 and are set using the two rotary switches on the top of each I/O module. One switch is for the 1's digit and the other for the 10's digit of the Module ID. Figure 6 shows some examples of Module ID's.

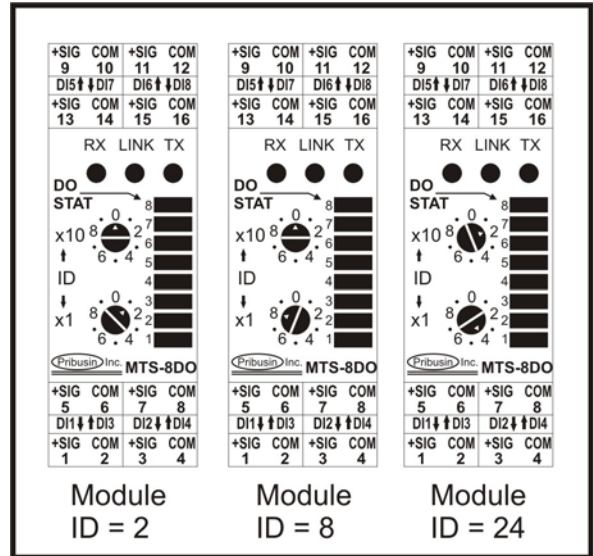

Figure 6

Figure 7 shows a typical MTS system consisting of one Host Stack and two Remote Stacks.

Module ID's in a system do not have to be consecutive (Module ID's 4 & 5 are not present).

Only two modules can have the same Module ID: one of them is an input module, the other is an output module. Input and output modules may be located on either the Host or Remote stacks depending on which way the signal is intended to be sent.

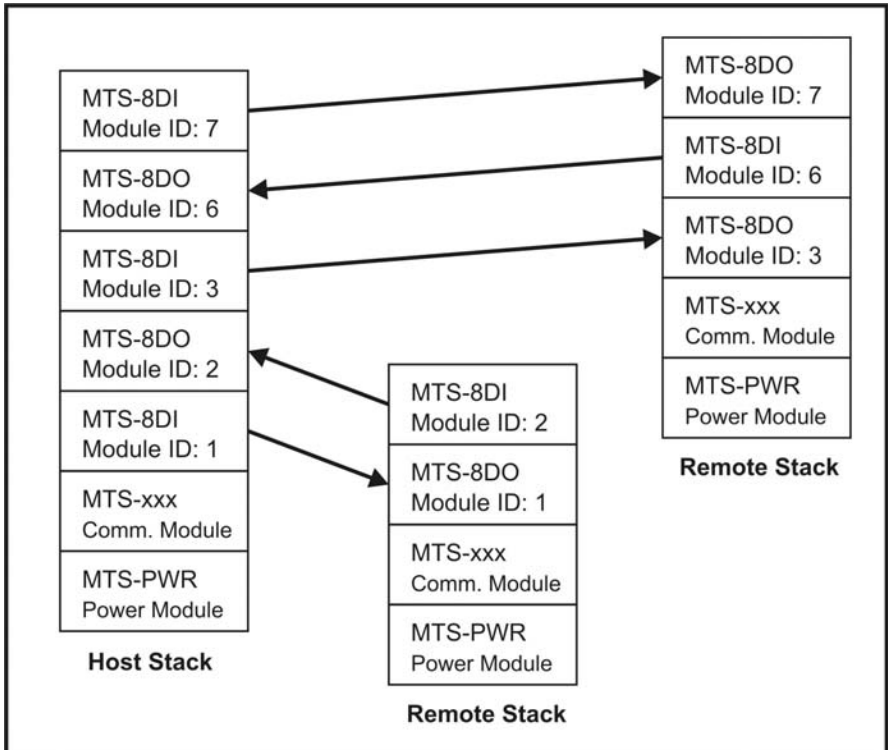

Figure 7

MTS-8DO Operation:

When an MTS system is first powered on, there is a brief time of inactivity (approx. 30 seconds) while the Communication Modules discover which I/O modules are present in their stack. After the discovery period is over, the modules on the Host Stack will begin communicating with their counter part modules on a Remote Stack. Communication occurs one module at a time and in numerical order for all Module ID's present on the Host Stack. A careful observer can witness this by the TX (transmit) and RX (receive) lights on each module.

Link Status Light:

Once two modules have communicated for the first time, they illuminate their Link lights to indicate that the modules have found each other and that a successful data exchange has taken place. This Link light will remain in a solid on state while communication between the two modules continues to be successful.

The Link light will flash when there is a problem with the communication between the two modules. Several flashing sequences indicate the nature of the problem.

Link Status	Description
Off	Undiscovered or No Power
On	Linked with other Module
1 Flash	Link with other Module Lost
2 Flashes	Linked with Wrong Module Type

A **single flash** indicates that the module has lost communication with its counterpart module. Reasons for this include, but are not limited to:

Problem	Check
'Other Stack' lost Power	<ul style="list-style-type: none"> Verify power on 'Other Stack' Check other Modules - Not likely if another Module from the 'Other Stack' is still communicating with a Module from 'This Stack'
Communication Module Bad on 'This Stack'	<ul style="list-style-type: none"> Check other Modules on 'This Stack' – Not Likely if any are still linked and communicating
Bad counter-part I/O Module on 'Other Stack'	<ul style="list-style-type: none"> Check TX/RX Lights on Module on 'Other Stack'
Bad I/O Module on 'This Stack'	<ul style="list-style-type: none"> Check TX/RX Lights on Module on 'This Stack'

The above table describes some scenarios that could result in lost communication. For further assistance please contact your local representative or Pribusin Inc.

A **double flash** indicates that the module is trying to communicate with a counter-part module that is not the correct input or output type. Examples of this are: 1) an analog module tries to communicate with a digital module or 2) an input module tries to communicate with another input module. This is most likely the result of improperly assigned Module ID's. Check all Module ID's carefully and make sure that modules with the same ID are the correct pair (one input and one output) and that they are of the same type (both digital or analog, but not mixed).

MTS System Overview:

This section describes the concept and operation of a typical MTS system. The example below uses two remote sites, labeled 'Remote 1' and 'Remote 2'. Following are important points to note when designing or installing an MTS system:

- Every MTS system has one Host Stack and one or more Remote Stacks
- Each stack consists of at least one power module (MTS-PWR), one communications module (MTS-xxx, see table below for xxx), and one or more I/O modules
- I/O modules are always paired (one input module and one output module)
- One module of each pair (either input module or output module) **MUST** be on the Host Stack
- Each module pair **MUST** use the same Module ID
- Modules may be arranged to send their signals from Host-to-Remote or Remote-to-Host depending on which stack the input and output modules are located

Figure 8 shows a typical two remote system with a mixture of I/O modules arranged in ways so that some modules send signals from the Host Stack to the Remote Stacks while other modules send signals from a Remote Stack back to the Host Stack.

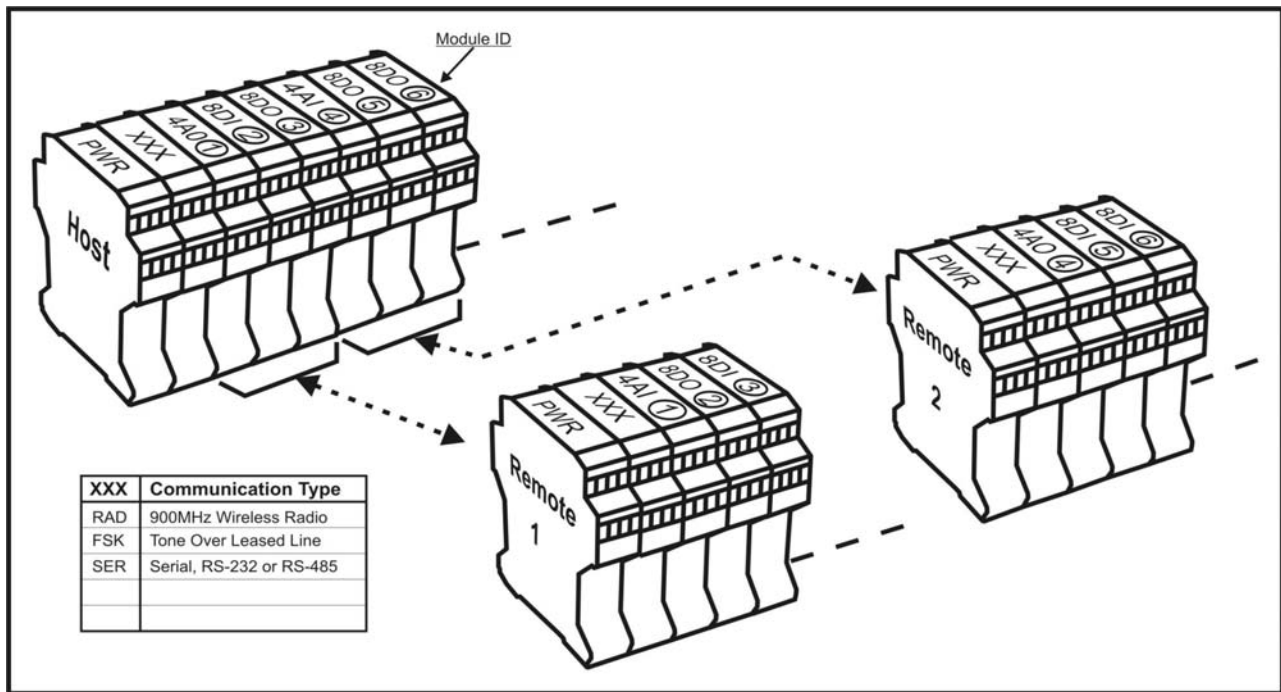

Figure 8

This table shows the modules that are currently available. Check our website at www.pribusin.com or with your local representative for the latest list of available modules.

Model No.	Description
MTS-RAD	900MHz Wireless Comm. Module
MTS-8DI	8 Channel Digital Input Module
MTS-8DO	8 Channel Digital Output Module
MTS-4AI	4 Channel Analog Input Module
MTS-4AO	4 Channel Analog Output Module
MTS-PWR	24VDC Power Module

Restocking Policy

All product returned to Pribusin Inc. in prime condition (not damaged, scratched or defaced in any way) within seven (7) months from the original date of shipment is subject to a 50% restocking charge. All product must be accompanied by a Return Authorization number (RA number) which must be obtained from Pribusin Inc. prior to returning any product.

After seven (7) months from the original date of shipment, products cannot be returned for restocking.

Custom designed products, modified products or all non-standard products may not be returned for restocking.

Warranty Policy

Pribusin Inc. warrants equipment of its own manufacture to be free from defects in material and workmanship, under normal conditions of use and service, and will replace any component found to be defective, on its return to Pribusin Inc., transportation charges prepaid, within one year of its original purchase. Pribusin Inc. will extend the same warranty protection on equipment, peripherals and accessories which is extended to Pribusin Inc. by the original manufacturer. Pribusin Inc. also assumes noliability, expressed or implied, beyond its obligation to prelace any component involved. Such warranty is in lieu of all other warranties, expressed or implied.