



*Manufacturers of Process
Controls and Instrumentation*

Instruction Manual

Model: *RCI-100-XXX*

Function: *Remote Control Signal Interface*

Communication: *XXX=SER: RS-232/485*
 XXX=MDM Modem Dial-Up
 XXX=FSK: Leased Line
 XXX=RFM: 2.4 Ghz Wireless

Input: 1 "Dry" Contact and 1 Analog Input

Output: 1 Form 'C' Contact and 1 Analog Output

Power: 117VAC, 50/60Hz
 24 VDC

Serial #: _____

(If special or required)

For Technical Assistance And Questions Call
USA: (231) 788-2900 CANADA: (905) 660-5336

Restocking Policy

All product returned to Pribusin Inc. in prime condition (not damaged, scratched or defaced in any way) within seven (7) months from the original date of shipment is subject to a 50% restocking charge. All product must be accompanied by a Return Authorization number (RA number) which must be obtained from Pribusin Inc. prior to returning any product.

After seven (7) months from the original date of shipment, products cannot be returned for restocking.

Custom designed products, modified products or all non-standard products may not be returned for restocking.

Warranty Policy

Pribusin Inc. warrants equipment of its own manufacture to be free from defects in material and workmanship, under normal conditions of use and service, and will replace any component found to be defective, on its return to Pribusin Inc., transportation charges prepaid, within one year of its original purchase. Pribusin Inc. will extend the same warranty protection on equipment, peripherals and accessories which is extended to Pribusin Inc. by the original manufacturer. Pribusin Inc. also assumes noliability, expressed or implied, beyond its obligation to prelace any component involved. Such warranty is in lieu of all other warranties, expressed or implied.

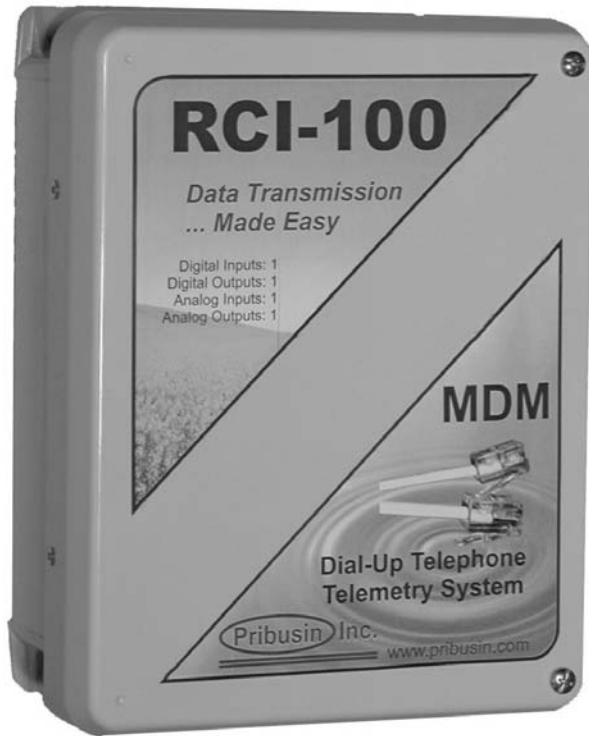

Standard Features:

- Bi-directional Communication using Phone Line
- Dial-Out Programmable for: Status/Setpoint Change, Incremental Signal Change and Timed Interval
- Point-to-Point or Host-to-Multi-Point Operation
- 1 Dry Contact and 1 Analog Input
- 1 'C' Relay Contact and 1 Analog Output
- Configurable to Initiate and/or Answer A Call
- Uses Standard Voice Telephone Line
- No Calibration Required
- Microprocessor Controlled for High Accuracy
- Power: 117 VAC 50/60 Hz (Optional 24 VDC)
- Built-in Overvoltage Protection on Telephone Line
- High Noise Rejection

Function:

The RCI-100-MDM is a bi-directional dial-up communication system that exchanges the status of 1 dry contact input and 1 analog input between a host and remote unit or a PC equipped with a modem. A basic system consists of A) one host station and one or more remote station(s) **OR** B) several remote stations and one PC with a modem.

In system A), the host unit can be set to interrogate the remote unit(s) periodically or when required. Remote units may also be configured to call the host when required. One host may operate several remote units.

In system B), a PC can call several remote units or alternately, remote units may call the PC when required

LabVIEW & Visual BASIC drivers are provided for user software development on PC's.

Connection:

Units are connected via a standard dial-up voice grade line. Regular J11 Phone Jacks make for easy installation. When connecting units on a PBX system make sure it can accept analog modem transmissions. Serial systems connect via standard modem cable.

Specifications:

Transmission Medium: Analog Voice Grade Phone Line
BAUD Rate: 2400 BAUD typ., 9600, 14.4K available
Operating Temperature: -20 Deg.C. to +50 Deg.C.
Relay Contacts: 10A 1/8Hp @ 125VAC
6A 1/8Hp @ 277VAC
Power: 117 VAC, 60/50 Hz
(24VDC Available)
Enclosure: NEMA4X (NEMA12 available as an option)
Approvals: ETL 3118354:
UL 60950-1-2007; CSA-C22.2 No. 60950-1-07

RCI-100-MDM

Enclosures & Dimensions:

Options: (Add letters to end of Model Number)

D - 8-Digit Scanning Display

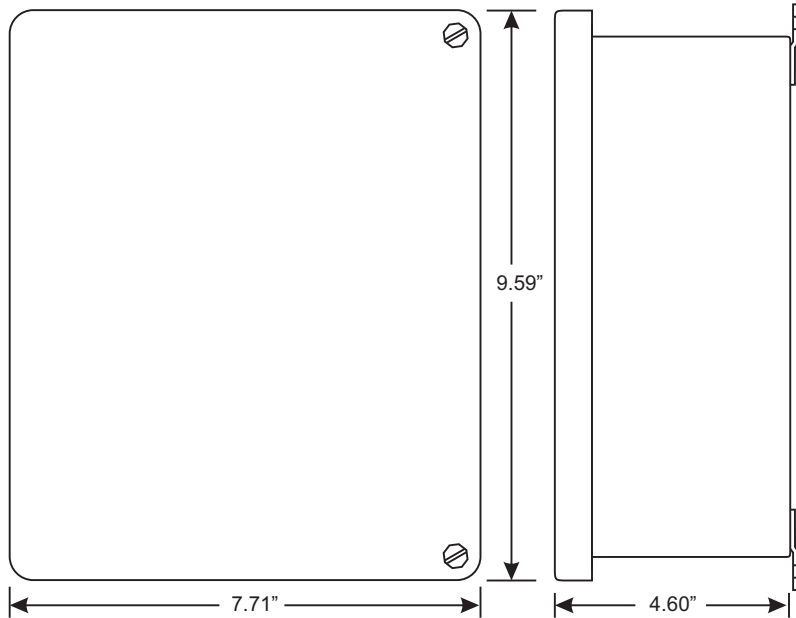

Connection:

1 Analog
1 Contact

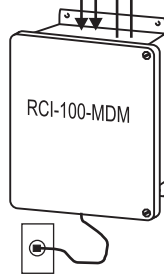

System A

1 Analog
1 Contact



System B

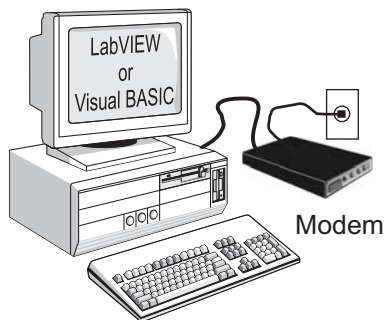

2 Analog
2 Contact



1 Analog
1 Contact

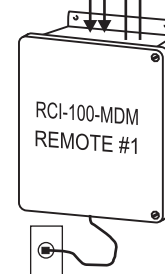

1 Analog
1 Contact

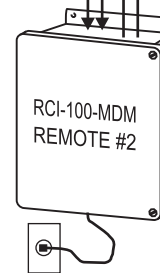

Manufactured By:

Pribusin Inc.

www.pribusin.com
info@pribusin.com

USA:

Pribusin Inc.
743 Marquette Ave.
Muskegon, MI 49442
Ph: (231) 788-2900
Fx: (231) 788-2929



CANADA:

Pribusin Inc.
101 Freshway Dr. Unit 57
Concord, Ontario, L4K 1R9
Ph: (905) 660-5336
Fx: (905) 660-4068

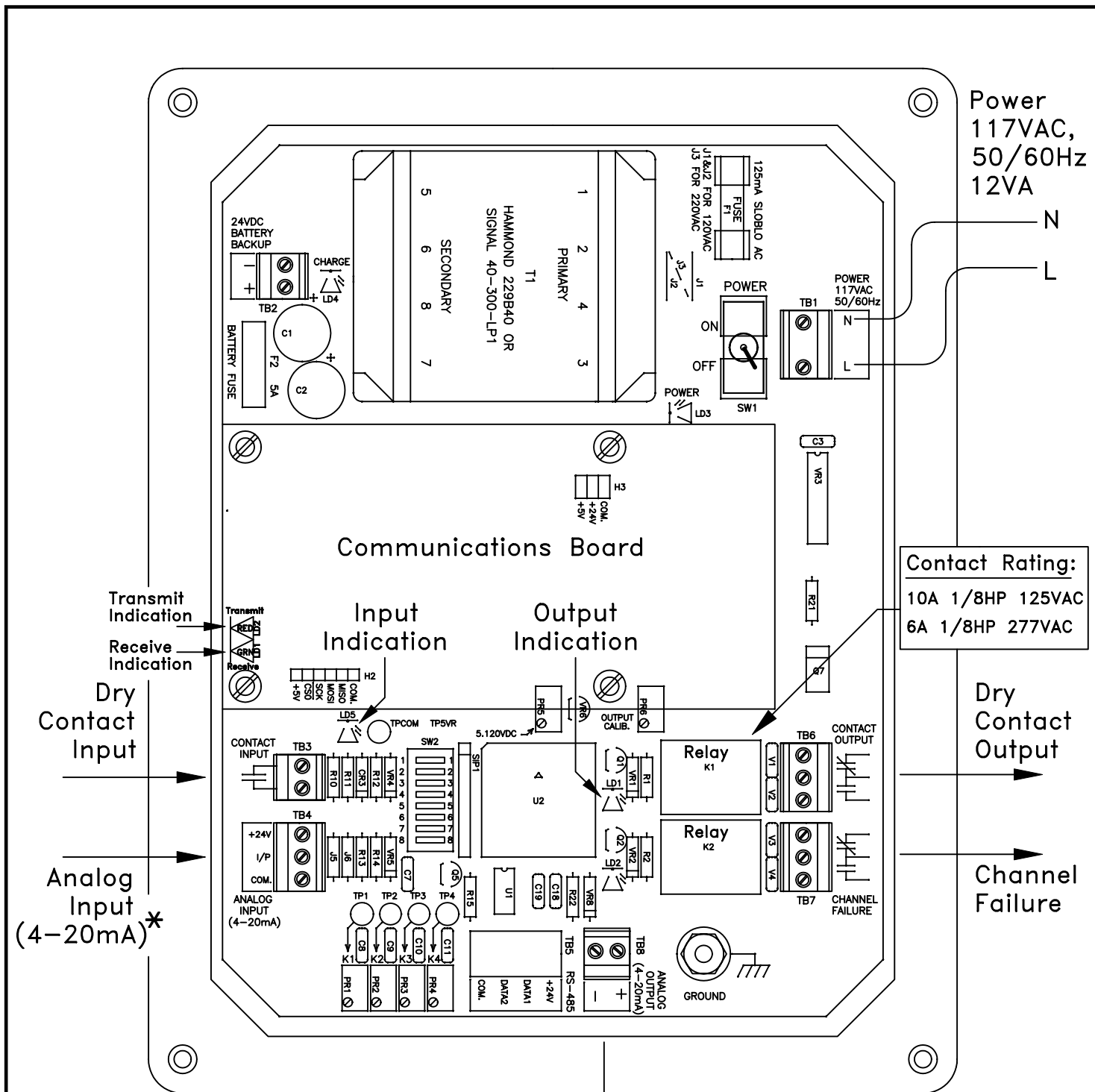

* 4-20 mA input and output ranges extend to 0 mA to 20 mA.

Analog Output (4-20mA)*

Pribusin Inc. ©		
CHKD:	DATE: Jan. 28/02	DRN: KS
Model: RCI-100-XXX Remote Control Signal Interface Panel Layout/Connections		
DWG. NO.:	106547	REV. A

RCI-100 Connections:

The RCI-100 is the main board of an RCI-100-XXX Telemetry system. It provides the input and output signal connections as well as the power supply for the unit. A separate communications board is added to the RCI-100 to allow it to communicate with other units. This communications board may have its own configuration that is in a separate section of this manual. The following configuration applies only to the RCI-100 board and is common to all communications interfaces.

AC Power & Fuse:

The RCI-100 is typically powered from 120VAC and protected by a 125mA SLOBLO fuse. It can be wired for 240VAC operation by removing (desoldering) power jumpers J1 & J2 and installing (soldering) jumper J3.

When changing the RCI-100 to 240VAC power make sure to change the fuse to half of its value, 62mA. This is important since at 240VAC the RCI-100 requires only half the current as if it were powered from 120VAC. Proper protection is only achieved by reducing the fuse value as mentioned above.

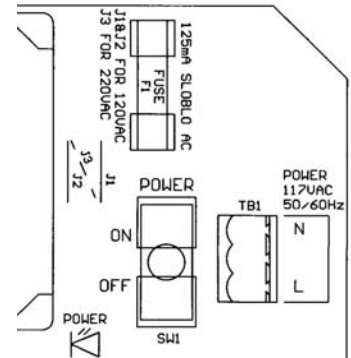

DC Power & Battery Backup:

The RCI-100 may also be powered from a 24VDC source which could be a battery or a DC power supply. The 24VDC power input is polarity protected with a fuse to prevent damage to the RCI-100 by inadvertent reverse polarity. A DC fuse provision is also provided if this power option is utilized. Insert a 5A automotive type blade fuse into the Battery Fuse socket.

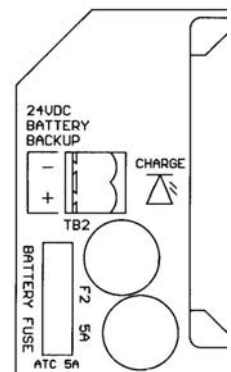

Inputs:

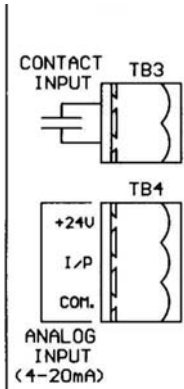

The RCI-100 has one dry contact input and one 0-20mA input. The dry contact input is excited with 24VDC and will source approximately 20mA when the contact is closed. A red LED lights up when the contact input is closed.

The analog input is configured as a 0-20mA input and has a 250 Ω input impedance. The input terminal has three connections: +24V, I/P, COM. The +24V power output may be used to power field transmitters. Up to 500mA may be used to power a transmitter. The input signal is connected to I/P(+) and COM(-).

The analog input is connected to the RCI-800 in two fashions: 1) Normal (3-wire connection) or 2) two-wire connection. On a 3-wire connected input, an external power supply or the +24V power output terminal of the RCI provides power to the field transmitter. The field transmitter has a current source that provides the 4-20mA signal back to the RCI-100. If using the power supply of the RCI-100, the field transmitter may draw up to 125mA.

On a 2-wire connected input, the field transmitter receives power from the RCI-100 and superimposes the signal onto the power return path. A maximum of 20mA will flow in such a connection. Make sure to consult the field transmitter manual to determine how to connect it to the RCI-100.

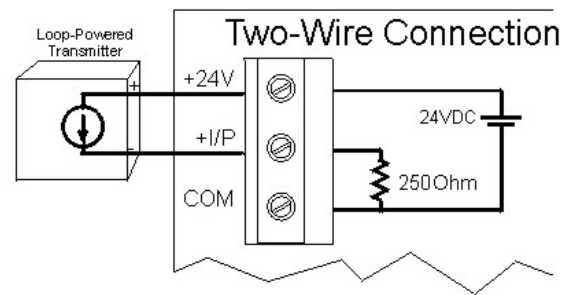
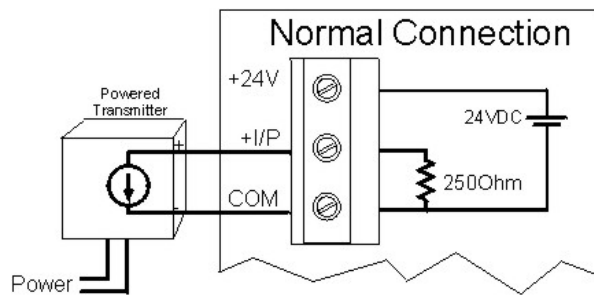

Outputs:

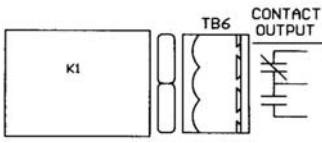

The RCI-100 has one form 'C' relay contact output and one 0-20mA analog output. The relay contact is capable of switching 120VAC, 10A or 240VAC, 6A. An energy absorbing varistor is installed across each contact to limit switching transients. A second relay contact acts as a communications fail indicator. If no communication occurred within 30 seconds, this relay contact will energize. Upon re-established communication this relay will de-energize again.

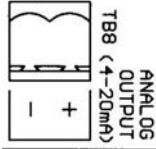

The analog output is typically configured as a 0-20mA output and can drive into a 1000Ω load, provided that the power supply to the unit is not below 24VDC. The output is not isolated from the input. Care must be taken when connecting the output to different devices so that no inadvertent ground loops are established.

Output Calibration & Input Testing:

The output on the RCI-100 is factory calibrated and should not require any adjustments. To check the calibration of the output and relays use switch SW2-7 & SW2-8 as shown below to set them to known states. If an output should require some adjustment, close SW2-8 only and turn the OUTPUT CALIB. trim pot until the output reads 20mA.

SW2-7	SW2-8	Function
OPEN	OPEN	Normal Operation
OPEN	CLOSED	Outputs=20mA, Relays=Energized
CLOSED	OPEN	Outputs=0mA, Relays=De-energized
CLOSED	CLOSED	Outputs=Inputs, Relays=Contact Inputs

If both switches are CLOSED, the analog and contact inputs are passed straight through to the analog and relay outputs. This may help in troubleshooting input and output signals.

Make sure both switches are OPEN before resuming normal operation.

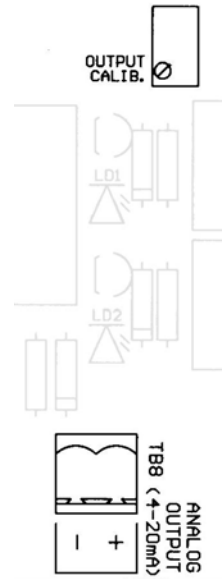

Battery Charger:

The RCI-100 has a battery connection that allows the system to remain powered up in the case of main power failure. The battery charger is designed to work with three (3) 6Volt lead-acid or gell-cell batteries. Switch SW2-6 to the CLOSED position to activate the battery charger. The charging LED will come on when the batteries are charging.

RCI-100 Configuration:

The RCI-100 requires no configuration other than for its communication fail operation. In the event of a communications failure on the communications board, the RCI-100 can be set up to take various actions on its outputs. This may be desirable in order to place connected devices into a safe operating mode. By default factory setting, all outputs remain at their last known state if a communications failure occurs.

SW2-	Function	OPEN	CLOSED
1	Relay Fail Mode	No Change	See SW2-2
2	Relay Fail Status	De-Energize	Energize
3	Output Fail Mode	No Change	Ramp to K1*
4			
5			
6	Battery Charger	Off	On
7	I/O Calibration		
8	I/O Calibration		

- * If SW2-3=CLOSED then the analog output will ramp to the setting of K1. The output will change at a rate determined by the setting of K2. The settings of the trim pots can be read on test points TP_{1,2} using a voltmeter. The test points read a voltage of 0-5V for a 0-100% adjustment.

$$TP_1 = \frac{Output}{20} \times 5Volt$$

$$TP_2 = \frac{RampRate}{60} \times 5Volt$$

where, *Output* = 0-20 (mA) and *Ramp Rate* = 0-60 (seconds) (5 sec. minimum)

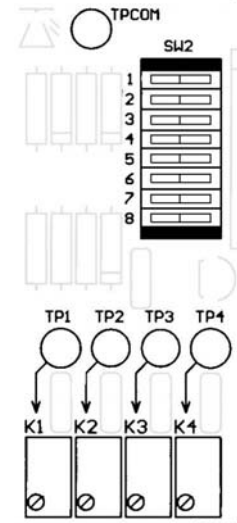

MDM Communication Option:

The -MDM communications option to the RCI series utilizes a 2400-BAUD modem to exchange the signal data between a host and its remote(s). There are two types of **Operating Modes** that can be configured: 1) Answer-Only and 2) Answer-and-Originate.

In **Answer-Only** mode the RCI-100-MDM will only answer incoming calls. It will not initiate calls to other devices. This is useful when only periodic data exchange is required. Typically a computer or PLC places a telephone call via a standard modem, the RCI-100-MDM answers and the two can now exchange data until the computer or PLC terminates the call.

In **Answer-and-Originate** mode the RCI-100-MDM operates just like in the Answer-Only mode with the additional capability of placing a call to another RCI-100-MDM or to a computer or PLC. A configuration procedure allows the programming of events or time intervals when the RCI-100-MDM is to place a call. This is useful where unattended, periodic data exchange is necessary. It is also useful when long distance charges apply to a call since the units can be programmed to communicate only when there is a change of status at one site or the other. Both units can be programmed to operate in the Answer-and-Originate mode thus providing bi-directional status change updates.

Modem configuration is done via a bank of DIP switches. The switches are located on the communications board just to the left of the telephone jack. They are either a slanted rocker type that flips **up for OFF** and **down for ON** or a flat rocker type that are marked **OPEN for OFF** and/or **CLOSED for ON**.

In Answer-Only mode, SW1 is used exclusively to set all operating parameters (see [Answer-Only Mode Configuration](#) below). In Answer-and-Originate mode, SW1 is not used and all switches must be in the OFF position. Instead the RS-232 connection is used to exchange a configuration file with a PC or laptop. This is necessary because of the large number of parameters that are required to be configurable for flexible dialing operation (see [Answer-and-Originate Mode Configuration](#) below).

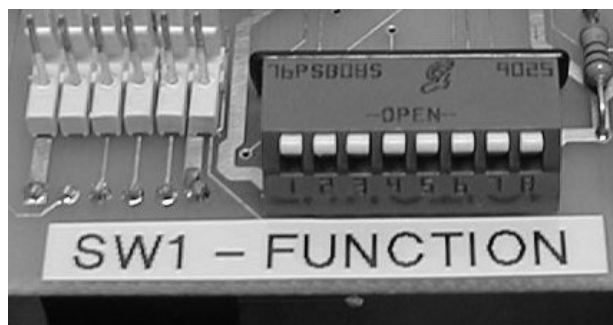

Answer-and-Originate Topologies:

The -MDM communications option to the RCI series utilizes dial-up telephone transmissions to exchange the signal data between a host and its remote(s). There are two types of **Topologies** that can be configured: 1) Point-to-Point and 2) Host-to-Multipoint.

In a **Point-to-Point** topology one host communicates with one remote. The two exchange all their signals with one another. The remote is configured as remote #1 even though it is the only remote in the system.

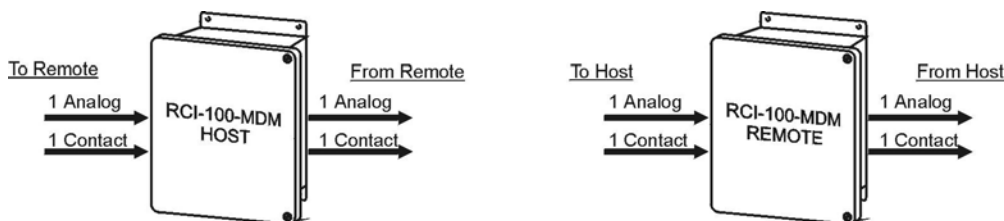

In a **Host-to-Multipoint** topology one host communicates to several remotes. Each remote is assigned an address (1,2,3, etc.) so that the host may distinguish between them. There may at most be as many remotes as there are inputs & outputs on the host.

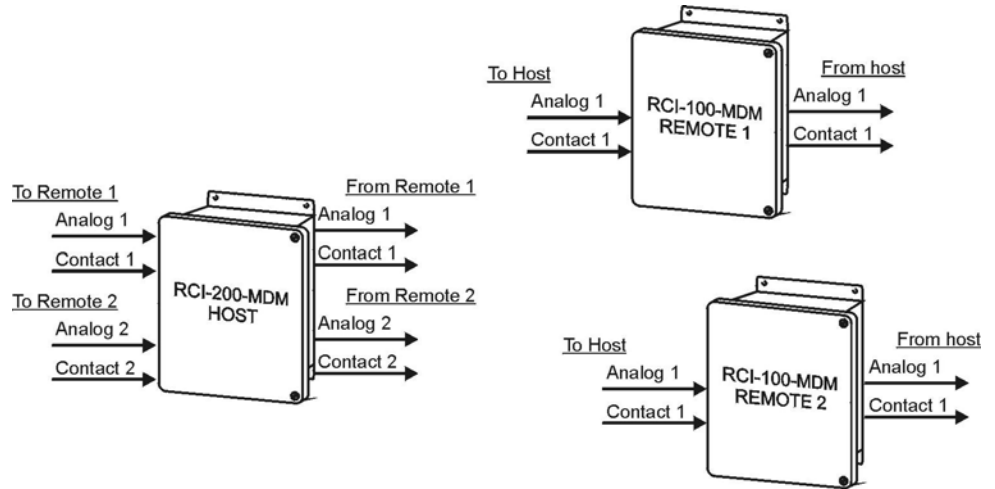

For example, an RCI-200 system, having two analog/contact inputs and outputs, may communicate with two RCI-100 remotes each having one analog/contact input and output. In this case all **#1 inputs and outputs on the host correspond to the #1 inputs and outputs on remote #1** and all **#2 inputs and outputs on the host correspond to the #1 inputs and outputs on remote #2**. The second analog/contact input and output on each of the two remotes would be unused.

Modem Mode Configuration:

The modem communication board has one bank of 8-position DIP switches: SW1. SW1-8 controls the mode of operation of the modem:

SW1-8	Modem MODE
OPEN	Answer-and-Originate (requires software configuration)
CLOSED	Answer-Only

Answer-Only Mode Configuration:

To make an RCI-100-MDM operate as an Answer-Only unit, make sure that SW1-8 is CLOSED.

Set the **number of rings** before the RCI-100-MDM is to answer using SW1-1, -2, -3. These switches are binary encoded as shown in the chart to the right. If the RCI-100-MDM is to ignore all incoming calls (during maintenance for example) make sure SW1-1, -2 & -3 are all in the OPEN position.

SW1-1	SW1-2	SW1-3	# of RINGS
OPEN	OPEN	OPEN	Don't Answer
CLOSED	OPEN	OPEN	1
OPEN	CLOSED	OPEN	2
CLOSED	CLOSED	OPEN	3
OPEN	OPEN	CLOSED	4
CLOSED	OPEN	CLOSED	5
OPEN	CLOSED	CLOSED	6
CLOSED	CLOSED	CLOSED	7

Next, set the **number of channels of each remote** using SW1-4, -5. One channel is considered 1 analog input/output plus 1 contact input/output. Hence an RCI-100 can have at most 2 channels.

SW1-4	SW1-5	Channels on Remotes
OPEN	OPEN	1
CLOSED	OPEN	2

RCI-MDM Configuration.vi

General

FIRMWARE It is very important that you select the correct firmware for your specific RCI-MDM unit. You can find this information by reading the top label of the microchip in your RCI-MDM. There are 3 types of Modems: 'K', 'L', and 'M'.

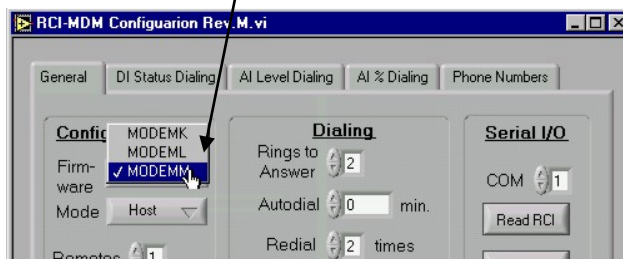
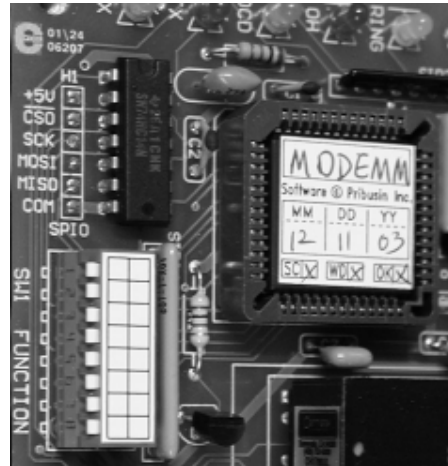

MODE This defines if the unit is a host or a remote. If it is a remote it further identifies the remote address. This is especially important in multi-remote systems.

Allowable values:

0 = Host, 1 thru 8 = Remote1 thru Remote8

REMOTES Number of remotes in the system. In a multi-remote system, this tells the host how many remotes it has to call when it initiates a call.

Allowable values: 1 thru 8

HOST CHANNELS Number of channels to be used on the host. All channels of all remotes in any system must add up to the number of channels on the host.

Allowable values: 1 thru 8

REMOTES CHANNELx Number of channels to be used on this remote. Total channels of all remotes in a multi-remote system must not exceed HOST CHANNELS. (x=1..8)

Allowable values: 1 thru 8

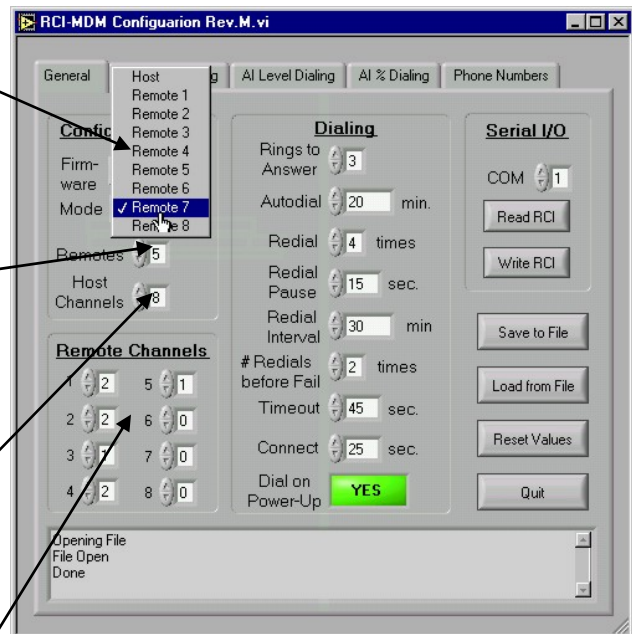

AUTODIAL The auto-dial time interval in minutes. If this parameter is set to 0 then the unit will NOT automatically initiate a call and will call only when a DI or AI status changes (see below). If this parameter is set to a value greater than 0 then the unit will place a call automatically in this time interval.

Allowable values:
 0 = no auto-dial
 1-65535 auto-dial interval (min.)

REDIAL Number of times the unit will attempt a re-dial if the previous dial failed to establish a connection (because of busy signal, reorder signal, etc.). If the unit does not establish a connection after the set number of redials it suspends the re-dial procedure for the specified Redial Interval minutes. New events that will require a call to be placed will re-initiate the dialing procedure.

Allowable values:
 0 = re-dial until successful
 1 thru 9 number of re-dials

REDIAL PAUSE Time interval, in seconds, the unit waits between re-dials. To prevent ongoing contention between units it is recommended that every unit in a system be assigned a different PAUSE interval. That way if two units happen to call at the same time, they wait different intervals before re-dialing.

Allowable values:
 10-255 = re-dial interval in seconds
 (note the 10 second minimum)

REDIAL INTERVAL Time interval, in minutes, the unit waits between each redial cycle. The unit will continue to execute redial cycles until a connection is established.

Allowable values:
 0-65535 = re-dial interval in minutes

RINGS The number of rings before the unit answers an incoming call.

Allowable values:
 0 = never answer a call
 1 thru 9 = rings before answer

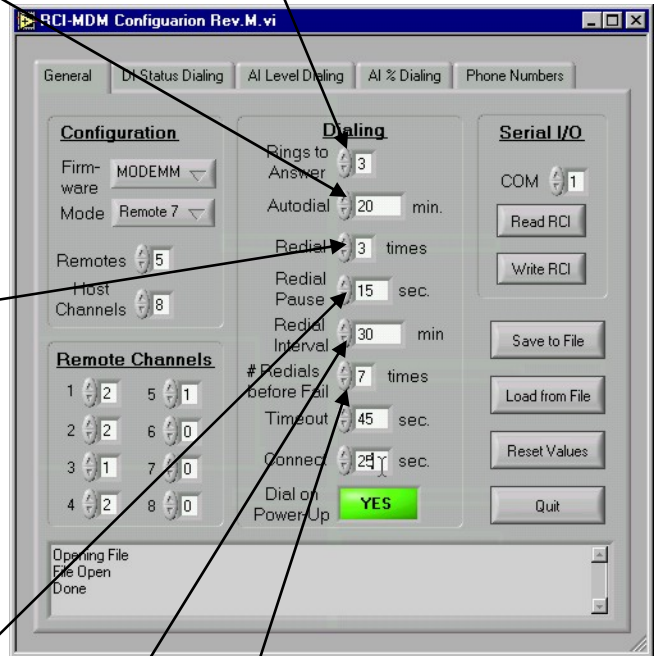

REDIAL FAIL Number of redials executed before the fail contact is activated.

Allowable values:
 0 = continuous
 1 thru 9 = attempts before fail signal

Redial Example Diagram

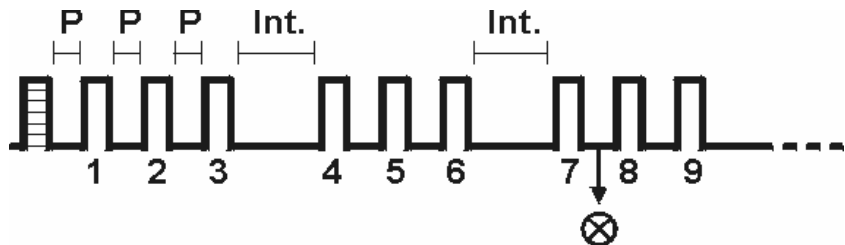
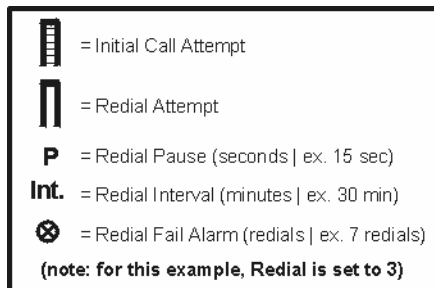

CONNECT Time interval, in seconds, the calling unit stays connected before it terminates the call. While two units are connected they continually exchange their data. This is useful when an immediate confirmation is required after sending an action to the other unit.

Allowable values:

5-255 = connection duration in sec.
(note the 5 second minimum)

TIMEOUT Time interval, in seconds, to wait for called unit to answer. If the called unit does not answer in this time, the call is considered unsuccessful.

Allowable values:

10-255 = wait interval in seconds
(note the 10 second minimum)

POWER-UP DIAL This setting determines if the unit will initiate a call at power-up. The unit can be forced to place a call in 'PAUSE' seconds after it is first powered up. This is useful to re-establish proper input and output settings after a power failure.

Allowable values:

NO = NO dial at power-up
YES = DIAL in PAUSE seconds after power-up

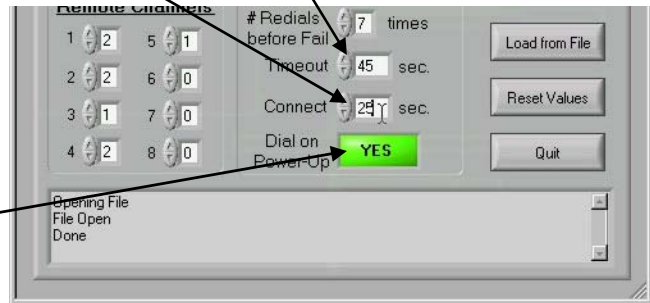

COM Select the COM Port to which the RCI-MDM is connected.

READ RCI Obtains configuration values that are stored in the RCI-MDM.

WRITE RCI Sends values to the RCI-MDM.

SAVE Allows you to save the configuration to a text file on your hard drive.

LOAD Allows you to load a configuration file from your hard drive.

RESET VALUES Resets all values to default settings.

QUIT Exits the Program.

DISPLAY Shows application processes, status and errors that occur.

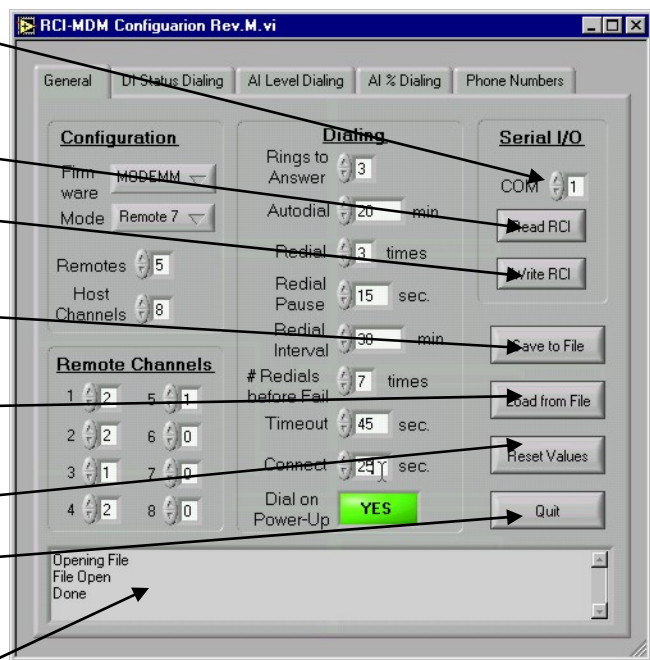

DI Status Dialing

Determines whether or not a call will be initiated when a **D**igital **I**nput changes its status. If **NO** is selected for an input, no call will be made if its status changes. However, if **YES** is selected, whenever that digital input switches from open-to-closed or closed-to-open, a call will be made.

If this unit is a remote, then a call will be placed to the host. If this unit is a host then a call will be placed to the remote that corresponds to this input channel.

Allowable values:

- NO = no call on status change
- YES = call on status change

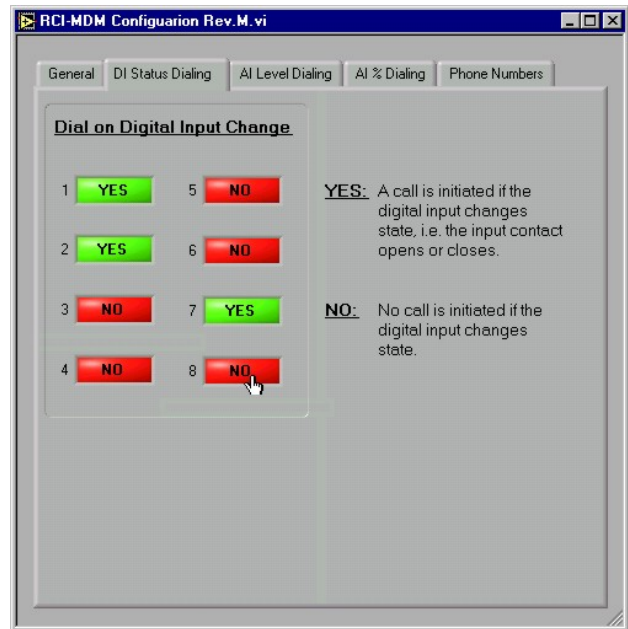

AI Level Dialing

Determines if a HIGH/LOW level on **A**nalog **I**nput x (x=1,2,..8) causes a call to be placed. If this unit is a remote, then a call will be placed to the host. If this unit is a host then a call will be placed to the remote that corresponds to this input channel.

A HIGH level occurs when the input value rises above this parameter. When the input level drops below 2% below this parameter the level is considered NORMAL and another call will be placed automatically.

A LOW level occurs when the input value falls below this parameter. When the input level rises above 2% above this parameter the level is considered NORMAL and another call will be placed automatically.

Allowable values:

- 0 = no call on HIGH and/or LOW level
- 1-65535 = call on HIGH and/or LOW level and call when HIGH and/or LOW level returns to NORMAL

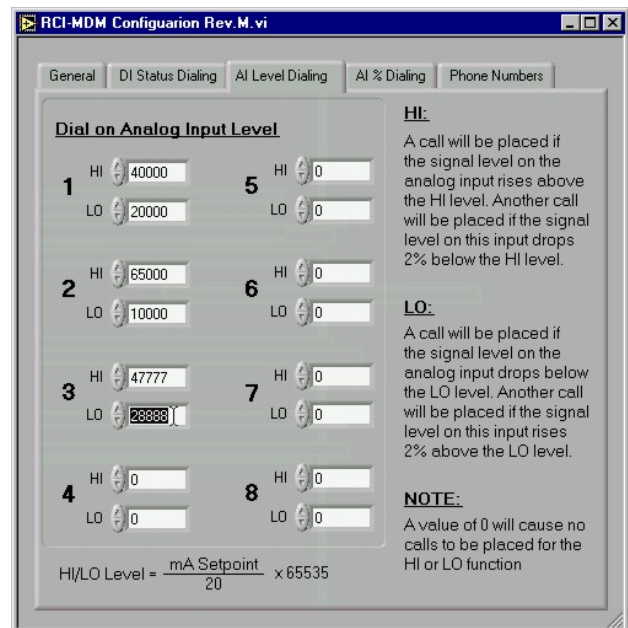

The parameter is calculated as follows:

$$\left[\text{PARAMETER} = \frac{\text{SETPOINT}(mA) - 4mA}{16mA} \times 65535 \right]$$

(where SETPOINT is between 4-20mA)

AI % Dialing

Determines if a specific amount of change on Analog Input x (x=1,2,..8) causes a call to be placed. If this unit is a remote, then a call will be placed to the host. If this unit is a host then a call will be placed to the remote that corresponds to this input channel.

The amount of change required before a call is placed is expressed as a percentage of full-scale signal. Be aware that a full-scale signal is from 0-20mA. Hence a 5% change would be 1mA. A call will be placed if the input signal either rises or falls more than the specified percentage compared to the signal level at the last call.

Allowable values:

0 = no call for percent change

1-50 = call on % change from NORMAL

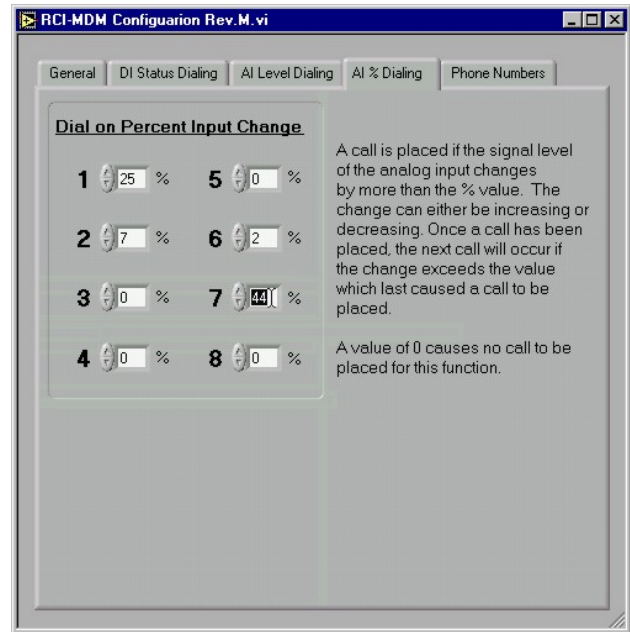

Phone Numbers

HOST The phone number of the host. It may be up to 15 characters long and may contain only digits and commas (,). A comma inserts a 2 second pause into the dialing sequence which may be necessary if the unit is on a PBX system where it needs to dial a number for an outside line and then wait before it dials the rest of the phone number.

REMOTE1 The phone number for REMOTE 1. The same rules apply as for the HOST

:

:

REMOTES8 The phone number for REMOTE 8. The same rules apply as for the HOST

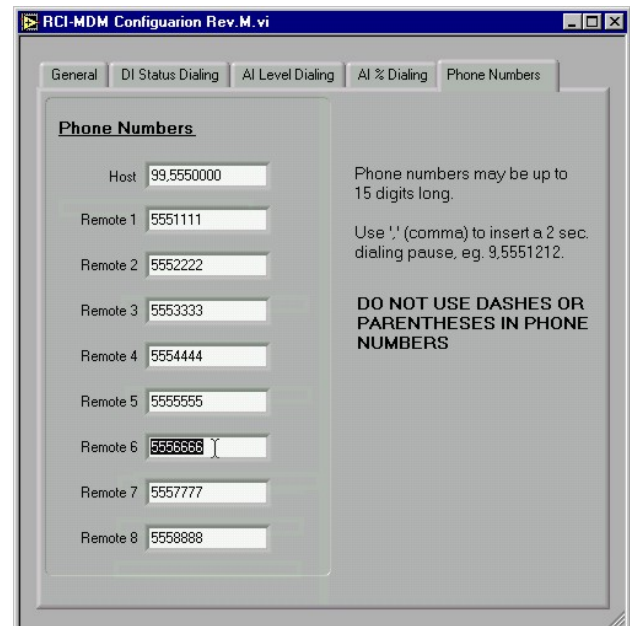

Downloading & Uploading Configuration Data:

To download the internal configuration data of the RCI-800-MDM or upload new configuration data it must first be placed in PROGRAMM mode.



1. Turn the power switch OFF.

2. Locate configuration jumper H7 on the modem board and insert jumper H7-1 only.

3. Locate Communication Select jumper H5 on the modem board and move the two jumpers from the NORM position into the PROG position.

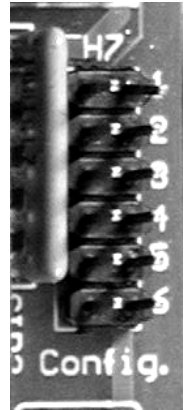

4. Connect the serial cable to the RS-232 connector on the modem board and to your serial port on your computer.

5. Make sure you have your serial port software running on your computer.

6. Turn the power switch back on and wait at least 5 seconds.

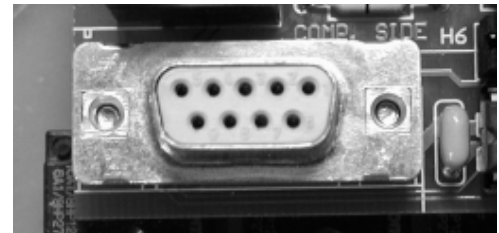

You can now download and upload configuration data as many times as necessary until the unit is configured properly. We suggest that you download the configuration data again after you have uploaded it to make sure that the RCI-800-MDM accepted it properly.

Upon completion **turn the power switch OFF again**, remove jumper H6-1, move jumpers H5 back to the NORM position, disconnect the serial cable and finally **turn the power switch back on**.

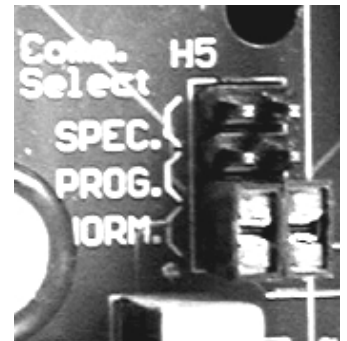

Download Configuration Data:

1. Make sure your serial software is ready to capture incoming serial data.

2. Press the DIAL button on the modem board.

3. The RCI-800-MDM will now send all of its internal configuration data, which is being captured, to a file by the computer. The red TX (transmit) LED will light or blink during this operation and you should see the data on your screen. When the red TX LED stops flashing the download is complete.

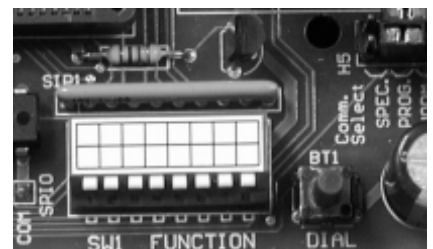

Note: If you are not receiving any data on your computer one possible reason may be that your Transmit and Receive lines in the RS-232 cable maybe crossed



Straight-Thru Cable



Null-Modem Cable

4. Stop the data capture on the serial port software.

You can now modify this file based on your requirements (see [Configuration File Details](#) below) and then upload the file back to the RCI-800-MDM.

Uploading Configuration Data:

Make sure your configuration file has been carefully modified so that it is free of errors.

1. Follow the file upload procedure for your serial port software to send the configuration file.
2. During the upload process you will see the green RX (receive) LED light or flash. Once the green LED stops flashing the upload process is complete and the RCI-800-MDM will reply with one of two messages:

CONFIG ERROR	The configuration file was received incorrectly or it has an error in it. Examine the file closely and/or try to re-send it.
SAVING CONFIGURATION	The file was received correctly and is now being stored in the RCI-800-MDM's non-volatile memory. Wait for the RCI-800-MDM to display the DONE message before moving on (this should take about 5 seconds)

Configuration File Details:

The RCI-800-MDM configuration file is a human-readable text file that defines the various operating parameters of the Answer-and-Originate Mode. The file is very simple in structure. Modifications can be made easily with a text-editing program however care must be taken to adhere to a few constraints.

1. The first line of the configuration file must read \$RCI-MDM. The '\$' is very important. During a configuration file upload the '\$' tells the RCI-800-MDM that a configuration file is being sent.
2. Any line starting with a semi-colon ';' is considered a comment line. There may be unlimited numbers of these lines in the configuration file. This is useful to make notes about the parameters to the user. *These comment lines are not stored in the RCI-800-MDM!*
3. The sequence of parameters may NOT be changed in any way.
4. The length of parameters must be exactly as present. If a parameter consists of 5 digits you must pad it with leading zero's to make it 5 digits long. Single digit parameters may only be one digit. *Be careful not to add any spaces at the end of the numbers!*
5. Phone numbers are exempt from constraint 4. They may be any length up to 15 characters.

Following is the default configuration file of an RCI-800-MDM as it is shipped from the factory. Note the large header at the top consisting of comment lines (starting with ;). This is a brief explanation of all the parameters and serves as a quick reference for a user who doesn't have access to this manual while performing a configuration.

```

$RCI-MDM
;
;RCI-XXX-MDM CONFIGURATION FILE
; - This file contains all operating parameters
; for the RCI-XXX-MDM. Sending this file to the
; RCI will reprogram the operating parameters
; to the values in this file.
;
; WHEN MODIFYING THIS FILE, MAKE SURE NOT TO
; DELETE OR ADD ANY LINES EXCEPT FOR COMMENT
; LINES THAT BEGIN WITH A ;
; FORMAT:
;
; [I/O CONFIGURATION]
; MODE=m          m = 0 - HOST
;                r = 1..8 - REMOTE (m=REMOTE NUMBER)
; REMOTES=r       r = 1..8 - NUMBER OF REMOTES
; CHANNELS REMOTE1=c c = 1..8 - CHANNELS ON REMOTE 1
; CHANNELS REMOTE2=c c = 1..8 - CHANNELS ON REMOTE 2
; CHANNELS REMOTE3=c c = 1..8 - CHANNELS ON REMOTE 3
; CHANNELS REMOTE4=c c = 1..8 - CHANNELS ON REMOTE 4
; CHANNELS REMOTE5=c c = 1..8 - CHANNELS ON REMOTE 5
; CHANNELS REMOTE6=c c = 1..8 - CHANNELS ON REMOTE 6
; CHANNELS REMOTE7=c c = 1..8 - CHANNELS ON REMOTE 7
; CHANNELS REMOTE8=c c = 1..8 - CHANNELS ON REMOTE 8
; HOST CHANNELS=c c = 1..8 - CHANNELS ON HOST
;
; [ANSWER]
; RINGS=r         r = 0 - NEVER ANSWER
;                = 1..9 - RINGS TO ANSWER
;
; [DIAL]
; AUTODIAL=mmmmmm mmmmmm = 00000 - NO AUTODIAL
; (mmmmmm=MINUTES)      = 00001..65535 - DIAL INTERVAL
; REDIAL=r             r = 0 - REDIAL UNTIL ANSWER
;                       = 1..9 - REDIALS IF BUSY OR NO ANSWER
; PAUSE=sssss         sssss = 00010..00255 - REDIAL PAUSE
; TIMEOUT=sssss       sssss = 00010..00255 - TIME TO WAIT FOR ANSWER
; CONNECT=sssss       sssss = 00000..00255 - TIME TO STAY CONNECTED
; (sssss=SECONDS)
; POWER-UP DIAL=d     d = 0 - NO DIAL AFTER POWER-UP
;                       1 - DIAL >PAUSE< SECONDS AFTER POWER-UP
;
; [PHONE NUMBERS]
; HOST=nnnnnnnnnnnnnn - PHONE NUMBER OF HOST
; REMOTEEx=nnnnnnnnnnnnnn - PHONE NUMBER OF REMOTE
; n = 0..9 (MAX. LENGTH IS 15 DIGITS INCLUDING ANY )
; = , TWO SECOND DIAL PAUSE
; EXAMPLE: 9,18005551212 IF 9=OUTSIDE LINE CODE
;
; [DI STATUS DIALING]
; DIXCHG=d          d = 0 - NO DIAL WHEN DIX CHANGES STATE
;                  = 1 - DIAL WHEN DIX CHANGES STATE
;
; x=1..8
;
; [AI LEVEL DIALING]
; AIX>=aaaaa       aaaaa = 00000 - NEVER DIAL ON AIX HIGH
; (HIGH SETPOINT)  = 00001..65535 - DIAL IF AIX >= aaaaa
; AIX<=aaaaa       aaaaa = 00000 - NEVER DIAL ON AIX LOW
; (LOW SETPOINT)   = 00001..65535 - DIAL IF AIX <= aaaaa
; aaaaa IS 16-BIT SETPOINT CALCULATED AS FOLLOWS:
; SETPOINT(mA) - 4mA
; ----- X 65535 = aaaaa
;          16mA
;
; [AI % CHANGE DIALING]
; AIX%CHG=aaaaa    aaaaa = 00000 - NEVER DIAL ON AIX CHANGE
; (% CHANGE)       = 00001..00050 - DIAL IF AIX % CHANGE > aaaaa
;                  (CHANGE CAN BE +VE OR -VE)
;
;

```

Above is the header portion of the configuration file. It serves as a quick reference and it is sent out by the RCI-800-MDM every time the configuration data is downloaded. It immediately precedes the actual configuration data.

```

; [I/O CONFIGURATION]
MODE=2
REMOTES=3
CHANNELS ON REMOTE1=2
CHANNELS ON REMOTE2=1
CHANNELS ON REMOTE3=2
CHANNELS ON REMOTE4=0
CHANNELS ON REMOTE5=0
CHANNELS ON REMOTE6=0
CHANNELS ON REMOTE7=0
CHANNELS ON REMOTE8=0
CHANNELS ON HOST=8
;
; [ANSWER]
RINGS=2
;
; [DIAL]
AUTODIAL=00000
REDIAL=2
PAUSE=00015
TIMEOUT=00030
CONNECT=00030
POWER-UP DIAL=0
;
; [PHONE NUMBERS]
HOST=6770060
REMOTE1=0000000000000000
REMOTE2=0000000000000000
REMOTE3=0000000000000000
REMOTE4=0000000000000000
REMOTE5=0000000000000000
REMOTE6=0000000000000000
REMOTE7=0000000000000000
REMOTE8=0000000000000000
;
; [DI STATUS DIALING]
DI1CHG=1
DI2CHG=0
DI3CHG=0
DI4CHG=0
DI5CHG=0
DI6CHG=0
DI7CHG=0
DI8CHG=0
;
; [AI LEVEL DIALING]
AI1>=50000
AI1<=20000
AI2>=00000
AI2<=00000
AI3>=00000
AI3<=00000
AI4>=00000
AI4<=00000
AI5>=00000
AI5<=00000
AI6>=00000
AI6<=00000
AI7>=00000
AI7<=00000
AI8>=00000
AI8<=00000
;
; [AI % CHANGE DIALING]
AI1%CHG=00010
AI2%CHG=00000
AI3%CHG=00000
AI4%CHG=00000
AI5%CHG=00000
AI6%CHG=00000
AI7%CHG=00000
AI8%CHG=00000
^

```

Above is the parameter portion of the configuration file. This is where changes can be made using a text-editing program.