



*Manufacturers of Process
Controls and Instrumentation*

Instruction Manual

Model: *RCI-100-XXX*

Function: *Remote Control Signal Interface*

Communication: *XXX=SER: RS-232/485*
 XXX=MDM Modem Dial-Up
 XXX=FSK: Leased Line
 XXX=RF9: 900 Mhz Wireless
 XXX=RF2: 2.4 Ghz Wireless

Input: 1 "Dry" Contact and 1 Analog Input

Output: 1 Form 'C' Contact and 1 Analog Output

Power: 117VAC, 50/60Hz
 24 VDC

Serial #: _____

(If special or required)

For Technical Assistance And Questions Call
USA: (231) 788-2900 CANADA: (905) 660-5336

Restocking Policy

All product returned to Pribusin Inc. in prime condition (not damaged, scratched or defaced in any way) within seven (7) months from the original date of shipment is subject to a 50% restocking charge. All product must be accompanied by a Return Authorization number (RA number) which must be obtained from Pribusin Inc. prior to returning any product.

After seven (7) months from the original date of shipment, products cannot be returned for restocking.

Custom designed products, modified products or all non-standard products may not be returned for restocking.

Warranty Policy

Pribusin Inc. warrants equipment of its own manufacture to be free from defects in material and workmanship, under normal conditions of use and service, and will replace any component found to be defective, on its return to Pribusin Inc., transportation charges prepaid, within one year of its original purchase. Pribusin Inc. will extend the same warranty protection on equipment, peripherals and accessories which is extended to Pribusin Inc. by the original manufacturer. Pribusin Inc. also assumes noliability, expressed or implied, beyond its obligation to prelace any component involved. Such warranty is in lieu of all other warranties, expressed or implied.

RCI-100-RF9

Enclosures & Dimensions:

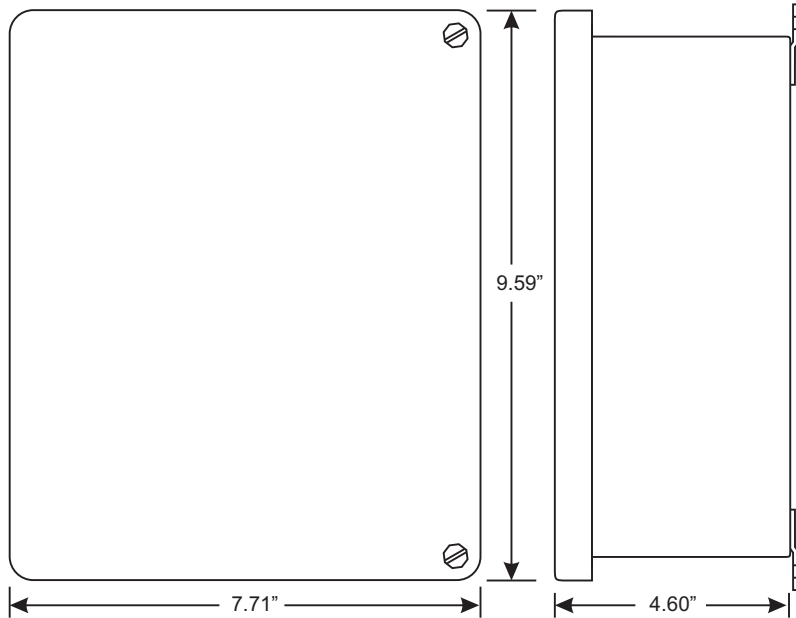

Connection:

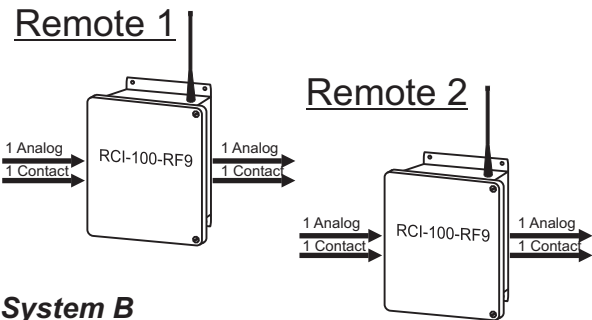
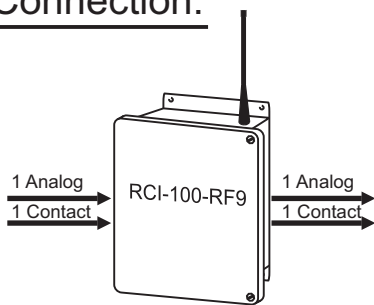

System B Master to Multi-Remote

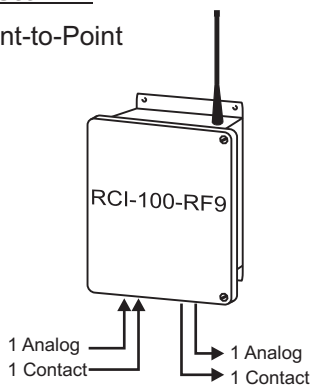

Master

OR

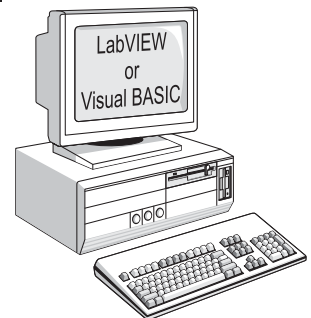
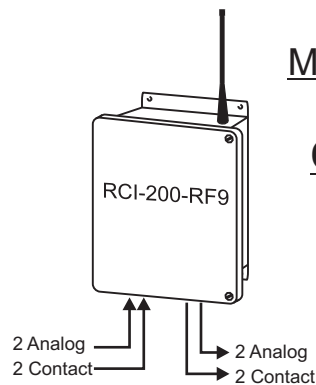

Manufactured By:

Pribusin Inc.

www.pribusin.com
info@pribusin.com

USA:

Pribusin Inc.
743 Marquette Ave.
Muskegon, MI 49442
Ph: (231) 788-2900
Fx: (231) 788-2929



CANADA:

Pribusin Inc.
101 Freshway Dr. Unit 57
Concord, Ontario, L4K 1R9
Ph: (905) 660-5336
Fx: (905) 660-4068

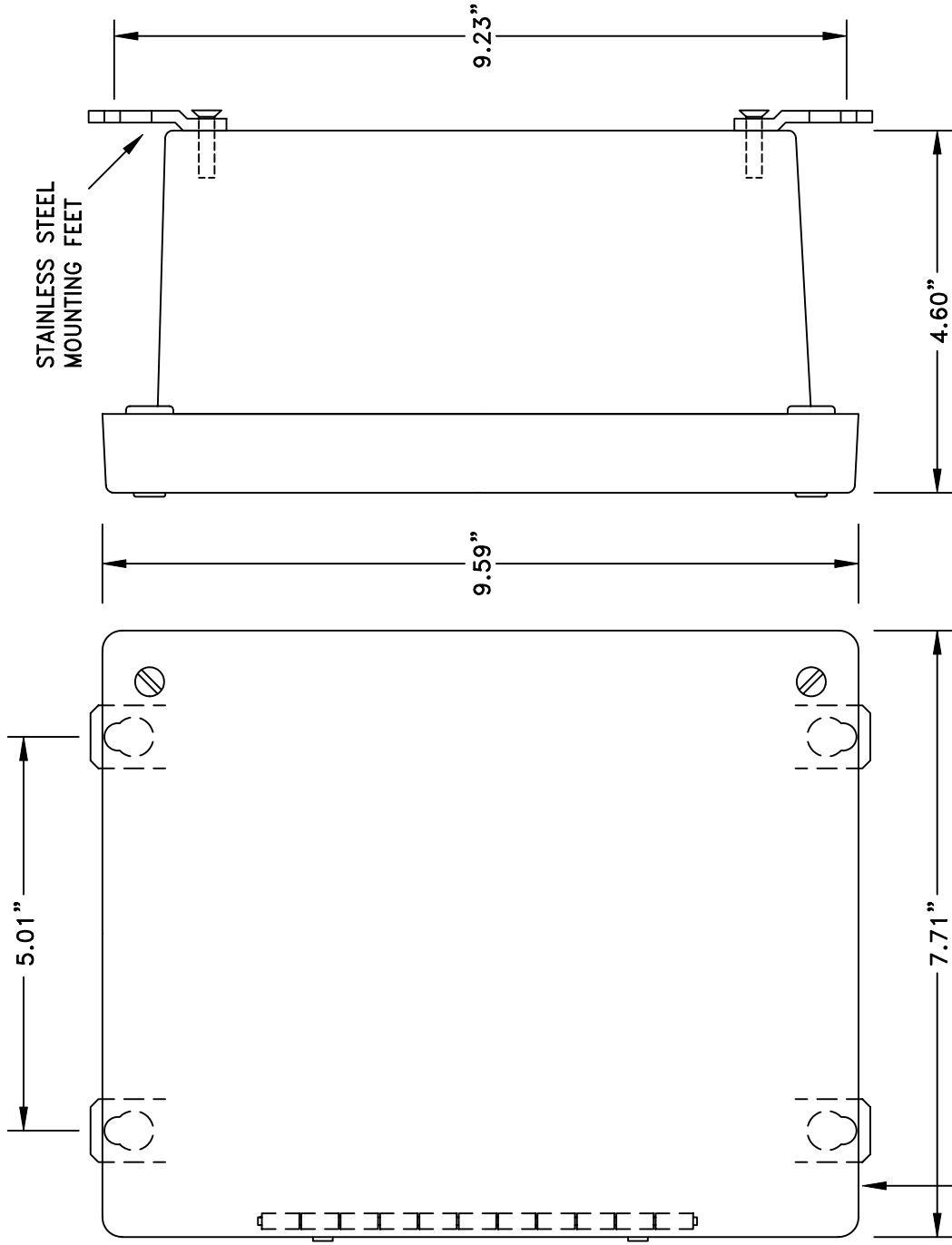

FRONT VIEW

SIDE VIEW

NEMA 4X AM SERIES FIBERGLASS ENCLOSURE
 WITH STAINLESS STEEL HINGE
 AND SCREW COVER

Pribusin Inc. ©		
CHKD:	DATE: OCT. 02/01	DRN: KS
NEMA 4X AM SERIES FIBERGLASS ENCLOSURE (BOX SIZE: 8" x 6" x 4")		
DWG. NO.:	106470-2	REV. A

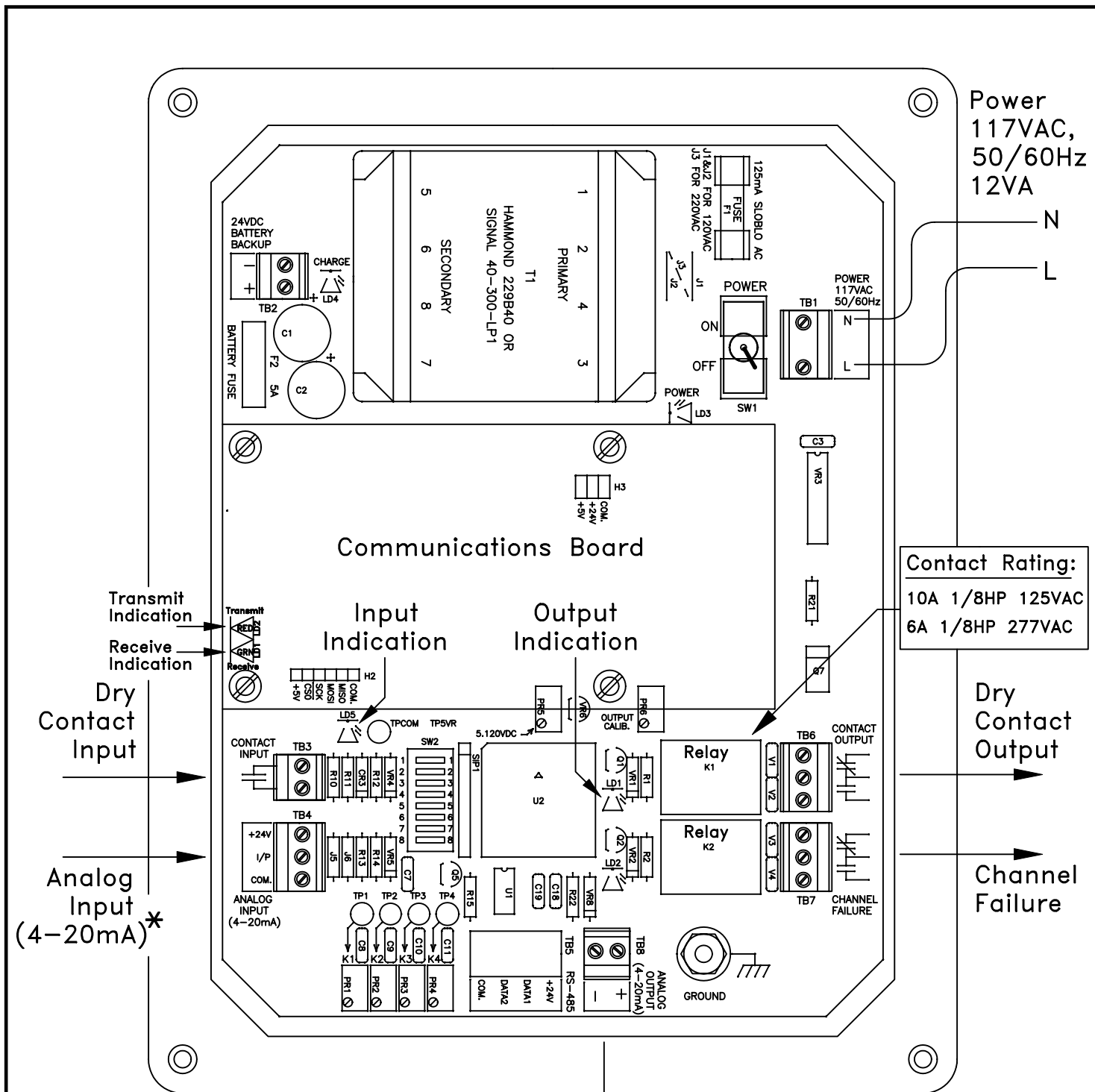

Power
117VAC,
50/60Hz
12VA

Contact Rating:
10A 1/8HP 125VAC
6A 1/8HP 277VAC

Transmit Indication
Receive Indication
Dry Contact Input
Analog Input (4-20mA)*

Dry Contact Output
Channel Failure

* 4-20 mA input and output ranges extend to 0 mA to 20 mA.

Analog Output (4-20mA)*

Pribusin Inc. ©		
CHKD:	DATE: Jan. 28/02	DRN: KS
Model: RCI-100-XXX Remote Control Signal Interface Panel Layout/Connections		
DWG. NO.:	106547	REV. A

RCI-100 Connections:

The RCI-100 is the main board of an RCI-100-XXX Telemetry system. It provides the input and output signal connections as well as the power supply for the unit. A separate communications board is added to the RCI-100 to allow it to communicate with other units. This communications board may have its own configuration that is in a separate section of this manual. The following configuration applies only to the RCI-100 board and is common to all communications interfaces.

AC Power & Fuse:

The RCI-100 is typically powered from 120VAC and protected by a 125mA SLOBLO fuse. It can be wired for 240VAC operation by removing (desoldering) power jumpers J1 & J2 and installing (soldering) jumper J3.

When changing the RCI-100 to 240VAC power make sure to change the fuse to half of its value, 62mA. This is important since at 240VAC the RCI-100 requires only half the current as if it were powered from 120VAC. Proper protection is only achieved by reducing the fuse value as mentioned above.

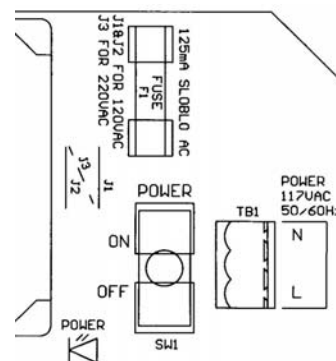

DC Power & Battery Backup:

The RCI-100 may also be powered from a 24VDC source which could be a battery or a DC power supply. The 24VDC power input is polarity protected with a fuse to prevent damage to the RCI-100 by inadvertent reverse polarity. A DC fuse provision is also provided if this power option is utilized. Insert a 5A automotive type blade fuse into the Battery Fuse socket.

If a battery is used, it must be an 18VDC Lead-Acid type rechargeable battery. This battery is most easily made up of three 6VDC batteries connected in series. We suggest using a spill-proof gel-cell type battery to prevent accidental leakage of the corrosive acid inside the batteries. The size of the batteries can vary from 1Ah to 20Ah depending on the length of time the RCI is to operate on battery power. Keep in mind that it takes 20 times longer to bring a 20Ah battery back to full charge compared to a 1Ah battery.

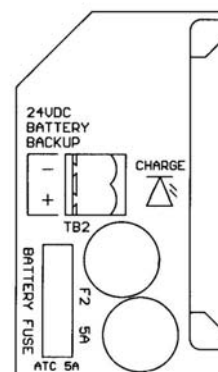

To enable the internal battery charging circuit, turn on switch SW1-6.

Inputs:

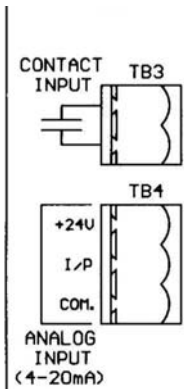

The RCI-100 has one dry contact input and one 0-20mA input. The dry contact input is excited with 24VDC and will source approximately 20mA when the contact is closed. A red LED lights up when the contact input is closed.

The analog input is configured as a 0-20mA input and has a 250Ω input impedance. The input terminal has three connections: +24V, I/P, COM. The +24V power output may be used to power field transmitters. Up to 500mA may be used to power a transmitter. The input signal is connected to I/P(+) and COM(-).

The analog input is connected to the RCI-800 in two fashions: 1) Normal (3-wire connection) or 2) two-wire connection. On a 3-wire connected input, an external power supply or the +24V power output terminal of the RCI provides power to the field transmitter. The field transmitter has a current source that provides the 4-20mA signal back to the RCI-100. If using the power supply of the RCI-100, the field transmitter may draw up to 125mA.

On a 2-wire connected input, the field transmitter receives power from the RCI-100 and superimposes the signal onto the power return path. A maximum of 20mA will flow in such a connection. Make sure to consult the field transmitter manual to determine how to connect it to the RCI-100.

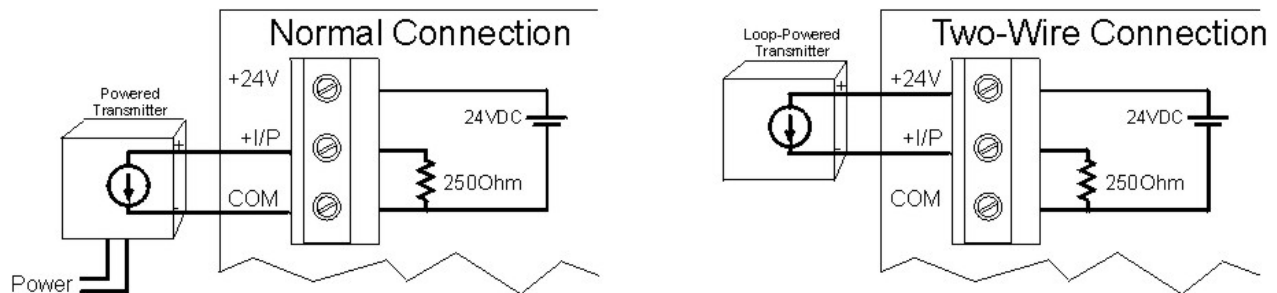

Outputs:

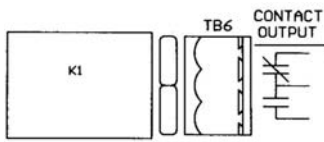

The RCI-100 has one form 'C' relay contact output and one 0-20mA analog output. The relay contact is capable of switching 120VAC, 10A or 240VAC, 6A. An energy absorbing varistor is installed across each contact to limit switching transients. A second relay contact acts as a communications fail indicator. If no communication occurred within 30 seconds, this relay contact will energize. Upon re-established communication this relay will de-energize again.

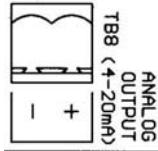

The analog output is typically configured as a 0-20mA output and can drive into a 1000Ω load, provided that the power supply to the unit is not below 24VDC. The output is not isolated from the input. Care must be taken when connecting the output to different devices so that no inadvertent ground loops are established.

Output Calibration & Input Testing:

The output on the RCI-100 is factory calibrated and should not require any adjustments. To check the calibration of the output and relays use switch SW2-7 & SW2-8 as shown below to set them to known states. If an output should require some adjustment, close SW2-8 only and turn the OUTPUT CALIB. trim pot until the output reads 20mA.

SW2-7	SW2-8	Function
OPEN	OPEN	Normal Operation
OPEN	CLOSED	Outputs=20mA, Relays=Energized
CLOSED	OPEN	Outputs=0mA, Relays=De-energized
CLOSED	CLOSED	Outputs=Inputs, Relays=Contact Inputs

If both switches are CLOSED, the analog and contact inputs are passed straight through to the analog and relay outputs. This may help in troubleshooting input and output signals.

Make sure both switches are OPEN before resuming normal operation.

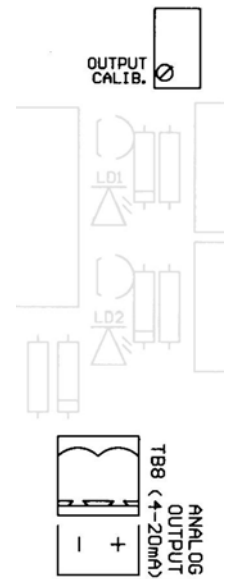

RCI-100 Configuration:

The RCI-100 requires no configuration other than for its communication fail operation. In the event of a communications failure on the communications board, the RCI-100 can be set up to take various actions on its outputs. This may be desirable in order to place connected devices into a safe operating mode. By default factory setting, all outputs remain at their last known state if a communications failure occurs.

SW2-	Function	OFF	ON
1	Relay Fail Mode	No Change	See SW2-2
2	Relay Fail Status	De-Energize	Energize
3	Output Fail Mode	No Change	Ramp to K1*
4			
5			
6	Battery Charger	OFF	ON
7	I/O Calibration		
8	I/O Calibration		

- * If SW2-3=CLOSED then the analog output will ramp to the setting of K1. The output will change at a rate determined by the setting of K2. The settings of the trim pots can be read on test points TP_{1,2} using a voltmeter. The test points read a voltage of 0-5V for a 0-100% adjustment.

$$TP_1 = \frac{Output}{20} \times 5Volt$$

$$TP_2 = \frac{RampRate}{60} \times 5Volt$$

where, *Output* = 0-20 (mA) and *Ramp Rate* = 0-60 (seconds) (5 sec. minimum)

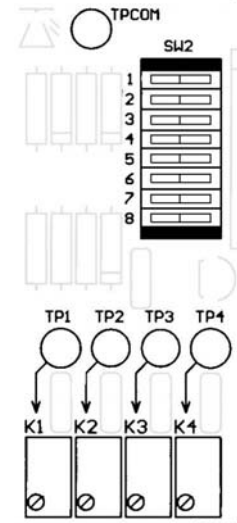

RF9 Communication Option:

The –RF9 communications option to the RCI series utilizes license-free 902-928 MHz spread spectrum radio frequency transmissions to exchange the signal data between a host and its remote(s). There are two types of **Topologies** that can be configured: 1) Point-to-Point and 2) Host-to-Multipoint.

In a **Point-to-Point** topology one host communicates with one remote. The two exchange all their signals with one another. The remote is configured as remote #1 even though it is the only remote in the system.

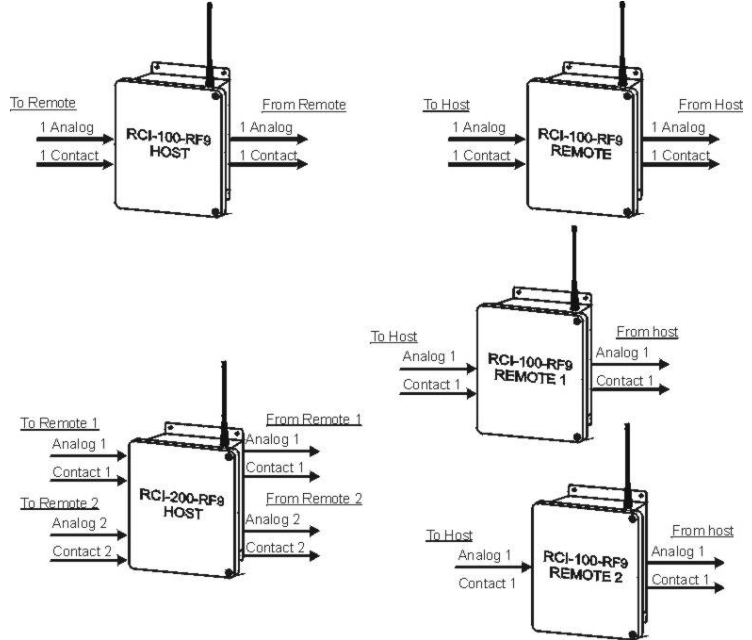

In a **Host-to-Multipoint** topology one host communicates to several remotes. Each remote is assigned an address (1,2,3, etc.) so that the host may distinguish between them. There may at most be as many remotes as there are inputs & outputs on the host.

For example, an RCI-200, having two analog/contact inputs and outputs, may communicate with up to two RCI-100 remotes each having one analog/contact input and output. In this case all **#1 inputs and outputs on the host correspond to the #1 inputs and outputs on remote #1** and all **#2 inputs and outputs on the host correspond to the #1 inputs and outputs on remote #2**. The second analog/contact input and output on each of the two remotes would be unused.

A **Network ID** allows multiple RFM systems to co-exist within close proximity without interfering with one another. There are four Network ID's to choose from: A, B, C or D. The host and its remote(s) must be set to the same Network ID in order for them to communicate with each other.

All radio configurations are done via two banks of DIPswitches. SW1 assigns the remote address from 1 to 100 using a binary encoding scheme. SW2 assigns the Topology, Network ID, Channel Numbers and Host/Remote Mode. The switches are located on the communications board just below the radio. They are a slanted rocker type that flips **up for OFF** and **down for ON**.

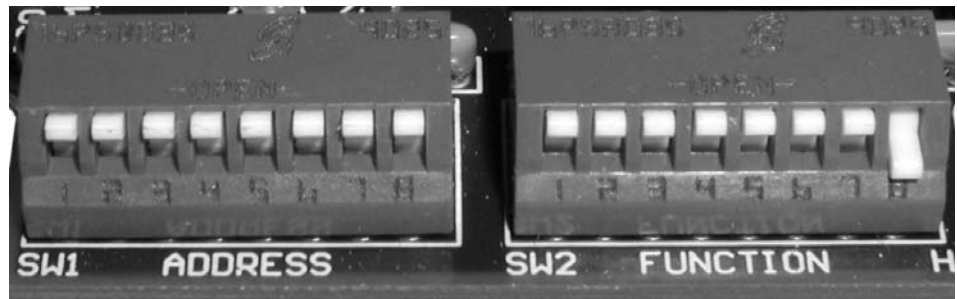

Radio Configuration:

The radio communication board has two banks of 8-position DIPswitches: SW1 and SW2. The function of these switches is slightly different for a host unit and a remote unit. We recommend powering the unit down while making any changes to the configuration.

SW1-	HOST	REMOTE
1	# of Remotes	Remote Address
2	# of Remotes	Remote Address
3	# of Remotes	Remote Address
4	Communication Timeout	PHP
5	Communication Timeout	PHP
6		PHP
7		
8	Repeater Select	Repeater Select

SW2-	HOST	REMOTE
1	# of Channels on each Remote	# of Channels on this Remote
2	# of Channels on each Remote	# of Channels on this Remote
3	# of Channels on Host	SHP
4	# of Channels on Host	SHP
5	Network ID	Network ID
6	Network ID	Network ID
7	RF Output Power	RF Output Power
8	Host / Remote Select	Host / Remote Select

Network ID:

The Network ID is common to both the host and remote modes of operation. All hosts and remotes that are intended to communicate with each other must be set to the same Network ID. Four ID's are available: A, B, C, D. They are set as shown in the table.

SW2-5	SW2-6	Network ID
UP	UP	A
DOWN	UP	B
UP	DOWN	C
DOWN	DOWN	D

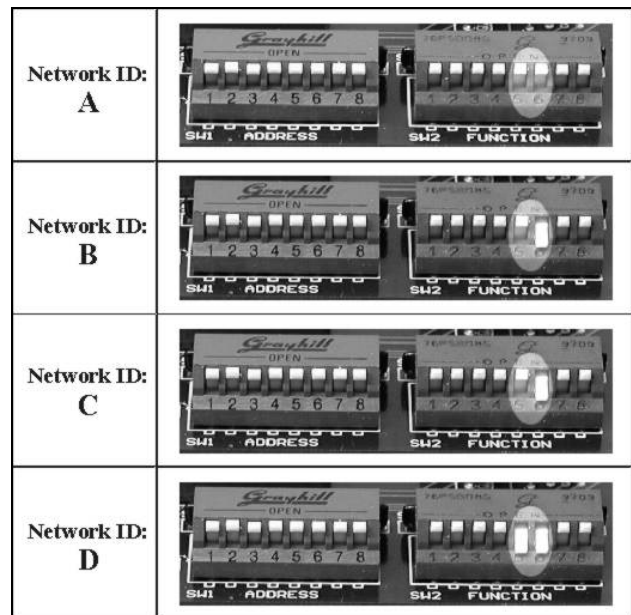

RF Output Power:

The radio output power can be selected with SW2-7. For shorter transmission ranges select the 100mW range to limit the amount of 'RF pollution'. Select the 1W setting for: a) longer transmission ranges, b) heavy foliage transmission scenarios, c) if there is no communication at the 100mW setting, or d) if the signal strength is less than -93dBm.

SW2-7	RF Power
UP	100 mW
DOWN	1 W

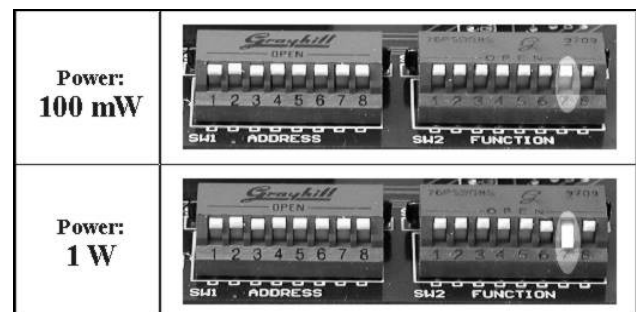

Host Configuration:

To make an RCI-100 operate as a host unit, make sure that SW2-8 is flipped down.

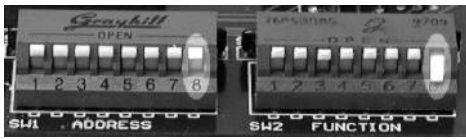

Next, set the **number of remotes** that the host is to communicate with using SW1-1, -2, -3. These switches are binary encoded as shown in the chart to the right.

SW1-1	SW1-2	SW1-3	# of Remotes
UP	UP	UP	1

Next, set the **number of channels of each remote** using SW2-1, -2. One channel is considered 1 analog input/output plus 1 contact input/output. Hence an RCI-100 can have at most 1 channel.

SW2-1	SW2-2	Channels on Remotes
UP	UP	1

Next, set the **number of channels of the host** using SW2-3, -4. An RCI-100 can at most have 1 channel. This is the number of channels that will be exchanged between the host and each remote.

SW2-3	SW2-4	Channels on Host
UP	UP	1



Optional (for repeater networks)

If you are using a repeater in your network or if the RCI system is located in a heavy interference area, you may need to adjust the **communication timing**. Since the radios have built in error correction algorithms to insure reliable and error free communication this can sometimes cause the communication to slow down by a few 10ths of a second. To compensate for this slow-down, the **communication timing** gives the data packets returning from the remote additional time to reach the host.

SW1-4	SW1-5	Communication Timing (seconds)
UP	UP	Full Speed
DOWN	UP	0.2sec delay
UP	DOWN	0.4sec delay
DOWN	DOWN	0.6sec delay

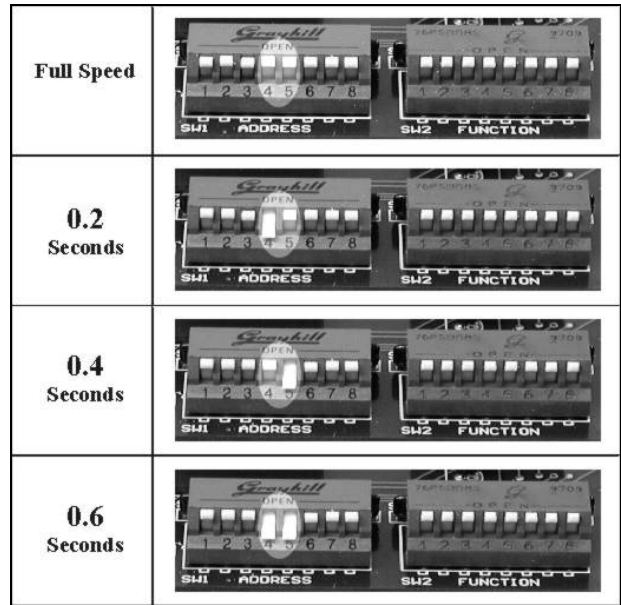

Remote Configuration:

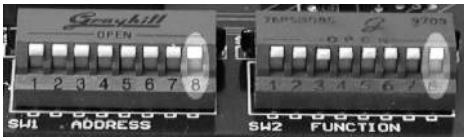

To make an RCI-100 operate as a REMOTE unit, make sure that SW2-8 is flipped up.

SW1-1	SW1-2	SW1-3	Remote Address
UP	UP	UP	1
DOWN	UP	UP	2
UP	DOWN	UP	3
DOWN	DOWN	UP	4
UP	UP	DOWN	5
DOWN	UP	DOWN	6
UP	DOWN	DOWN	7
DOWN	DOWN	DOWN	8

Next, set the **remote address** using SW1-1, -2 & -3. Each remote in a system must have a unique address.

Address: 1		Address: 5	
Address: 2		Address: 6	
Address: 3		Address: 7	
Address: 4		Address: 8	

Next, set the **number of channels on this remote** using SW2-1, -2. One channel is considered 1 analog input/output plus 1 contact input/output. Hence an RCI-100 can have at most 1 channel.



SW2-1	SW2-2	Channels on Remotes
UP	UP	1
DOWN	UP	2

Perform the next step only if this remote is communicating to the host via a repeater!!!

Next, set the **remote PHP** using SW1-4, -5, -6. The PHP of the repeater must match the SHP of the unit before it. If this is a host than set the repeater PHP=1.

SW1-4	SW1-5	SW1-6	REMOTE PHP
UP	UP	UP	1
DOWN	UP	UP	2
UP	DOWN	UP	3
DOWN	DOWN	UP	4
UP	UP	DOWN	5
DOWN	UP	DOWN	6
UP	DOWN	DOWN	7
DOWN	DOWN	DOWN	8

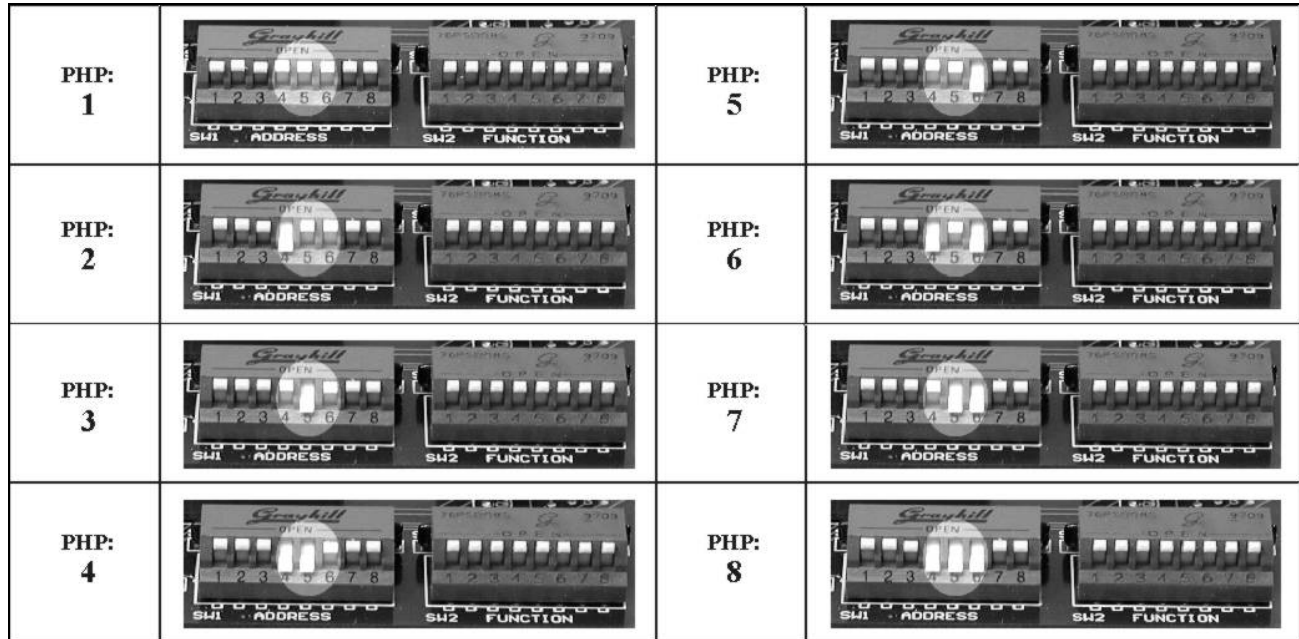

Remote with Repeater (optional)

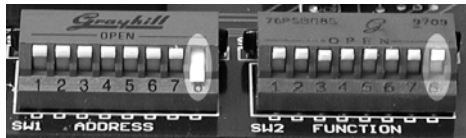

To make an RCI-100 operate as a remote-repeater unit, make sure that SW1-8 is flipped down and SW2-8 is flipped up.

In this mode, the unit will function like any other remote. In addition, the unit will be able to send data to remotes whose PHP is set to the same as the remote-repeater's SHP.

To set the **Secondary Hop Pattern (SHP)** for a remote-repeater, use switches SW2-3, -4. The SHP on a remote/repeater starts at 2. The Primary Hop Pattern (PHP) of remotes that communicate via this remote/repeater must match this SHP.

SW2-3	SW2-4	SHP
UP	UP	2
DOWN	UP	3
UP	DOWN	4
DOWN	DOWN	5

SHP: 2	
SHP: 3	
SHP: 4	
SHP: 5	

Point-to-Point Communication

Communication between one host and one remote is called point-to-point.

Example 1: An RCI-100 Host communicating with an RCI-100 Remote

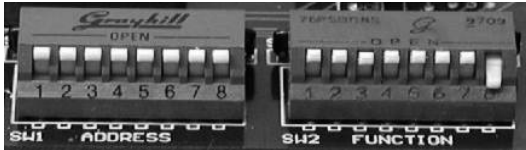

RCI-100 (Host)

Host Channels: **1**
 Number of Remotes: **1** Network ID: **A**
 Channels on Remotes: **1** Power: **100mW**

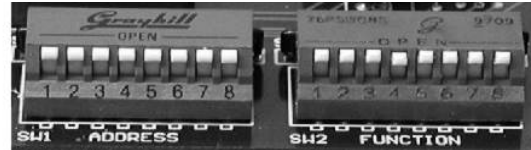

RCI-100 (Remote)

Remote Channels: **1**
 Address: **1** Network ID: **A**
 PHP: **1** Power: **100mW**

Example 2: An RCI-200 Host communicating with an RCI-200 Remote

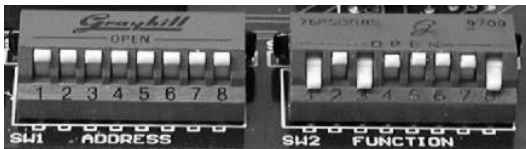

RCI-200 (Host)

Host Channels: **2**
 Number of Remotes: **1** Network ID: **A**
 Channels on Remotes: **2** Power: **100mW**

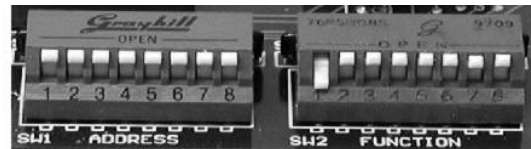

RCI-200 (Remote)

Remote Channels: **2**
 Address: **1** Network ID: **A**
 PHP: **1** Power: **100mW**

Example 3: An RCI-400 Host communicating with an RCI-400 Remote

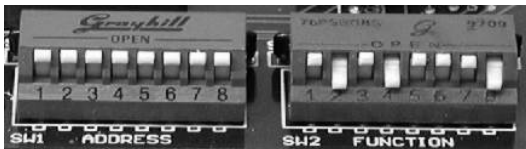

RCI-400 (Host)

Host Channels: **4**
 Number of Remotes: **1** Network ID: **A**
 Channels on Remotes: **4** Power: **100mW**

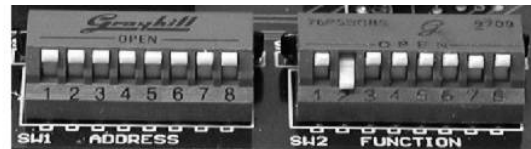

RCI-400 (Remote)

Remote Channels: **4**
 Address: **1** Network ID: **A**
 PHP: **1** Power: **100mW**

Example 4: An RCI-800 Host communicating with an RCI-800 Remote



RCI-800 (Host)

Host Channels: **8**
 Number of Remotes: **1** Network ID: **A**
 Channels on Remotes: **8** Power: **100mW**



RCI-800 (Remote)

Remote Channels: **8**
 Address: **1** Network ID: **A**
 PHP: **1** Power: **100mW**

Point-to-Multipoint Communication

Communication between a host and more than one remote is called point-to-multipoint.

Example 1: An RCI-200 Host communicating with (2) RCI-100 Remotes

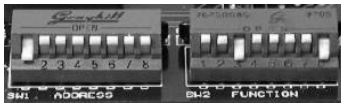

RCI-200 (Host)

Host Channels: **2**
 Number of Remotes: **2**
 Channels on Remotes: **1**
 Network ID: **A**
 Power: **100mW**



RCI-100 (Remote 1)

Remote Channels: **1**
 Address: **1**
 PHP: **1**
 Network ID: **A**
 Power: **100mW**



RCI-100 (Remote 2)

Remote Channels: **1**
 Address: **2**
 PHP: **1**
 Network ID: **A**
 Power: **100mW**

Example 2: An RCI-400 Host communicating with (2) RCI-200 Remotes



RCI-400 (Host)

Host Channels: **4**
 Number of Remotes: **2**
 Channels on Remotes: **2**
 Network ID: **B**
 Power: **100mW**

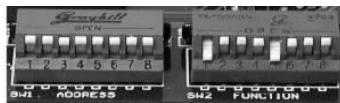

RCI-200 (Remote 1)

Remote Channels: **2**
 Address: **1**
 PHP: **1**
 Network ID: **B**
 Power: **100mW**

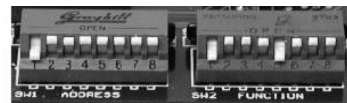

RCI-200 (Remote 2)

Remote Channels: **2**
 Address: **2**
 PHP: **1**
 Network ID: **B**
 Power: **100mW**

Example 3: An RCI-800 Host communicating with (2) RCI-400 Remotes



RCI-800 (Host)

Host Channels: **8**
 Number of Remotes: **2**
 Channels on Remotes: **4**
 Network ID: **C**
 Power: **1W**



RCI-400 (Remote 1)

Remote Channels: **4**
 Address: **1**
 PHP: **1**
 Network ID: **C**
 Power: **1W**



RCI-400 (Remote 2)

Remote Channels: **4**
 Address: **2**
 PHP: **1**
 Network ID: **C**
 Power: **1W**

Example 4: An RCI-800 Host communicating with (3) RCI-200 Remotes



RCI-800 (Host)

Host Channels: **8**
 Number of Remotes: **3**
 Channels on Remotes: **2**
 Network ID: **A**
 Power: **100mW**

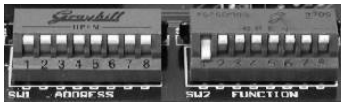

RCI-200 (Remote 1)

Remote Channels: **2**
 Address: **1**
 PHP: **1**
 Network ID: **A**
 Power: **100mW**



RCI-200 (Remote 2)

Remote Channels: **2**
 Address: **2**
 PHP: **1**
 Network ID: **A**
 Power: **100mW**

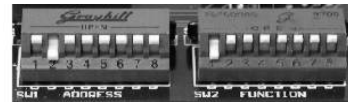

RCI-200 (Remote 3)

Remote Channels: **2**
 Address: **3**
 PHP: **1**
 Network ID: **A**
 Power: **100mW**

Example 5: An RCI-400 Host communicating with (3) RCI-100 Remotes via Repeater



RCI-400 (Host)

Host Channels: **4**
 Number of Remotes: **3**
 Channels on Remotes: **1**
 Network ID: **A**
 Power: **1W**



RCI-RPT (Repeater)

Repeater Number: **1**
 PHP: **1**
 SHP: **2**
 Network ID: **A**
 Power: **1W**



RCI-100 (Remote 1)

Remote Channels: **1**
 Address: **1**
 PHP: **2**
 Network ID: **A**
 Power: **1W**



RCI-100 (Remote 2)

Remote Channels: **1**
 Address: **2**
 PHP: **2**
 Network ID: **A**
 Power: **1W**



RCI-100 (Remote 3)

Remote Channels: **1**
 Address: **3**
 PHP: **2**
 Network ID: **A**
 Power: **1W**

Received Signal Strength Indicator (RSSI):



The radio communications board has a signal strength indicator to show the level of the signal that was received from another radio. The indicator consists of 3 LED's labeled 1, 2 & 3. It is desirable to operate with the highest signal strength achievable. If the signal strength is less than -93 dBm, it is advisable

to try to make adjustments to then system to bring the signal strength up. A higher power setting on the radio or a higher gain antenna can be used to increase signal strength and achieve more reliable operation of the radio system.

Signal Strength (dBm)	LED 1	LED 2	LED 3
-108	Flashing	Off	Off
-101	On	Off	Off
-93	On	Flashing	Off
-86	On	On	Off
-79	On	On	Flashing
-71	On	On	On