



*Manufacturers of Process  
Controls and Instrumentation*

# ***Instruction Manual***

Model: *RCI-800-XXX*

Function: *Remote Control Signal Interface*

Communication:  *XXX=SER: RS-232/485*  
 *XXX=MDM Modem Dial-Up*  
 *XXX=FSK: Leased Line*  
 *XXX=RFM: 2.4 Ghz Wireless*

Input:  8 "Dry" Contacts and 8 Analog Inputs

Output:  8 Form 'C' Contacts and 8 Analog Outputs

Power:  117VAC, 50/60Hz

24 VDC

Serial #: \_\_\_\_\_

*(If special or required)*

For Technical Assistance And Questions Call  
USA: (231) 788-2900 CANADA: (905) 660-5336

## Restocking Policy

**All product returned to Pribusin Inc. in prime condition (not damaged, scratched or defaced in any way) within seven (7) months from the original date of shipment is subject to a 50% restocking charge. All product must be accompanied by a Return Authorization number (RA number) which must be obtained from Pribusin Inc. prior to returning any product.**

**After seven (7) months from the original date of shipment, products cannot be returned for restocking.**

**Custom designed products, modified products or all non-standard products may not be returned for restocking.**

## Warranty Policy

**Pribusin Inc. warrants equipment of its own manufacture to be free from defects in material and workmanship, under normal conditions of use and service, and will replace any component found to be defective, on its return to Pribusin Inc., transportation charges prepaid, within one year of its original purchase. Pribusin Inc. will extend the same warranty protection on equipment, peripherals and accessories which is extended to Pribusin Inc. by the original manufacturer. Pribusin Inc. also assumes noliability, expressed or implied, beyond its obligation to prelace any component involved. Such warranty is in lieu of all other warranties, expressed or implied.**

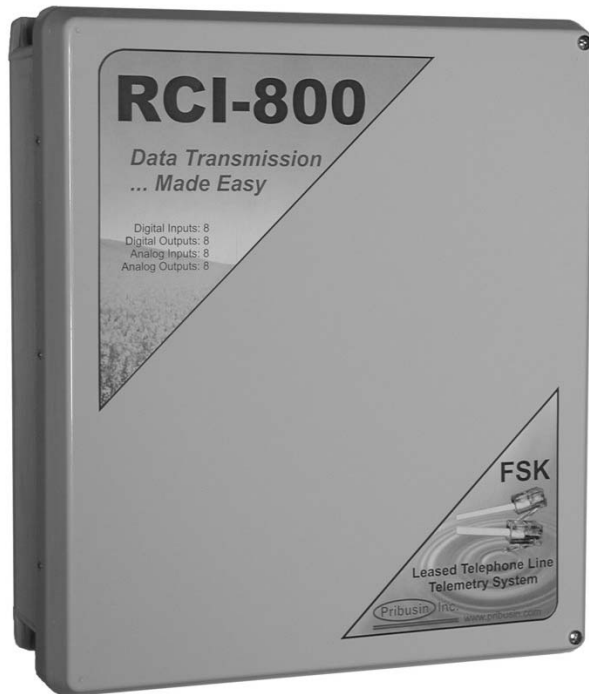

### Standard Features:

Bi-directional Communication using a Phone Line  
Uses MODBUS Protocol for Reliable Data Transfer  
8 Dry Contacts and 8 Analog Inputs  
8 'C' Relay Contacts and 8 Analog Outputs  
Uses Analog Half-Duplex Leased Telephone Line  
No Calibration Required  
Microprocessor Controlled for High Accuracy  
Power: 117 VAC 50/60 Hz (Optional 24 VDC)  
Built-in Overvoltage Protection on Telephone Line  
High Noise Rejection



### Function:

The RCI-800-FSK is a bi-directional remote communication system that exchanges the status of 8 dry contact inputs and 8 analog inputs between a master and remote unit. Both the master and remote unit have inputs and outputs to allow remote monitoring and remote control.

Since the master and remote units are connected via leased telephone line, and hence are 'always-on', a change in signal at one end is transmitted to the other end with very little delay. This makes this unit ideal for real-time monitoring of remote tanks, pumps, etc.

The bi-directional operation allows for control signals to be sent back to the remote site to take action based on the incoming monitored signal.

This unit may also be used as a remote unit in a multi-remote system where the master is a multi-channel device such as the RCI-800.

### Connection:

Units are connected via a class 'C' line (Dial-up or leased). Regular J11 Phone Jacks make for easy installation. When connecting units on a PBX system make sure it can accept analog modem transmissions. Serial systems connect via standard modem cable.

### Specifications:

Transmission Medium: Analog Phone Line, Half-Duplex  
BAUD Rate: 2400 BAUD  
Transmission Output: -6dB max., -8dB typ.  
Operating Temperature: -20 Deg.C. to +50 Deg.C.  
Relay Contacts: 10A 1/8Hp @ 125VAC  
6A 1/8Hp @ 277VAC  
Power: 117 VAC, 60/50 Hz  
(24VDC Available)  
Enclosure: NEMA4X (NEMA12 available as an option)  
Approvals: ETL 3118354;  
UL 60950-1-2007; CSA-C22.2 No. 60950-1-07

# RCI-800-FSK

## Enclosures & Dimensions:

**Options:** (Add letters to end of Model Number)

D - 8-Digit Scanning Display

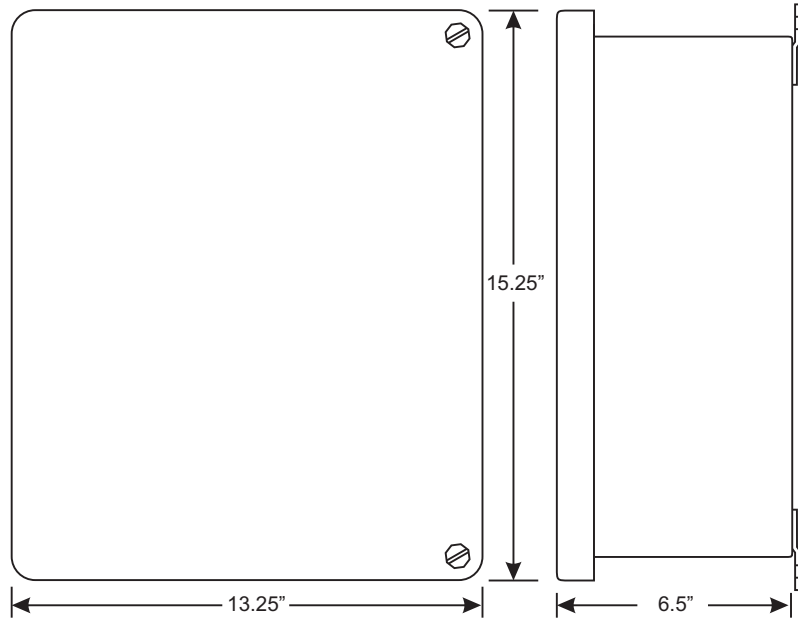

## Connection:

### 1. Point-to-Point System: 2 RCI-800-FSK Units

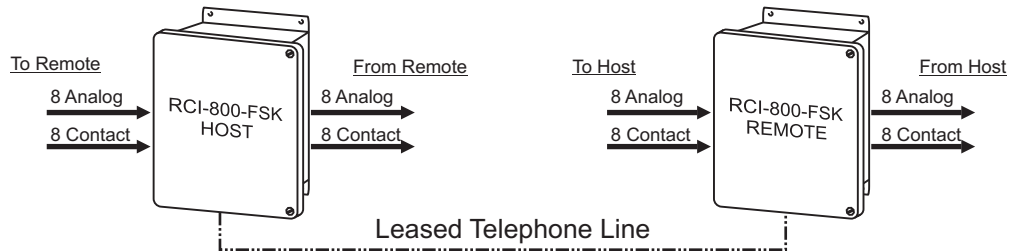

### 2. Host-to-Multi-Remote System:

- 1 RCI-800-FSK Host
- 2 RCI-400-FSK Remotes

This configuration provides **four** bi-directional analog and contact signal between one host unit and two remote units.

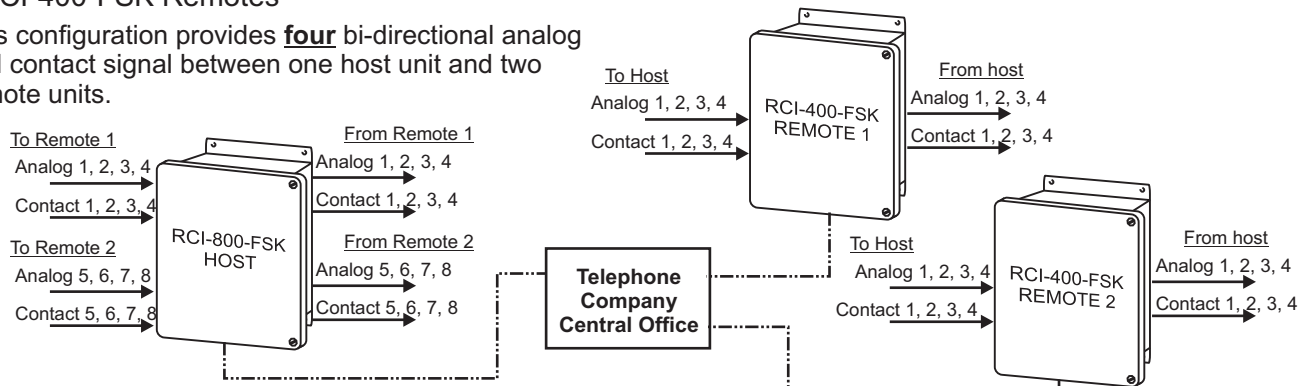

## Manufactured By:

**Pribusin Inc.**

[www.pribusin.com](http://www.pribusin.com)  
[info@pribusin.com](mailto:info@pribusin.com)

### USA:

Pribusin Inc.  
 743 Marquette Ave.  
 Muskegon, MI 49442  
 Ph: (231) 788-2900  
 Fx: (231) 788-2929



### CANADA:

Pribusin Inc.  
 101 Freshway Dr. Unit 57  
 Concord, Ontario, L4K 1R9  
 Ph: (905) 660-5336  
 Fx: (905) 660-4068

Mounting Holes  
10

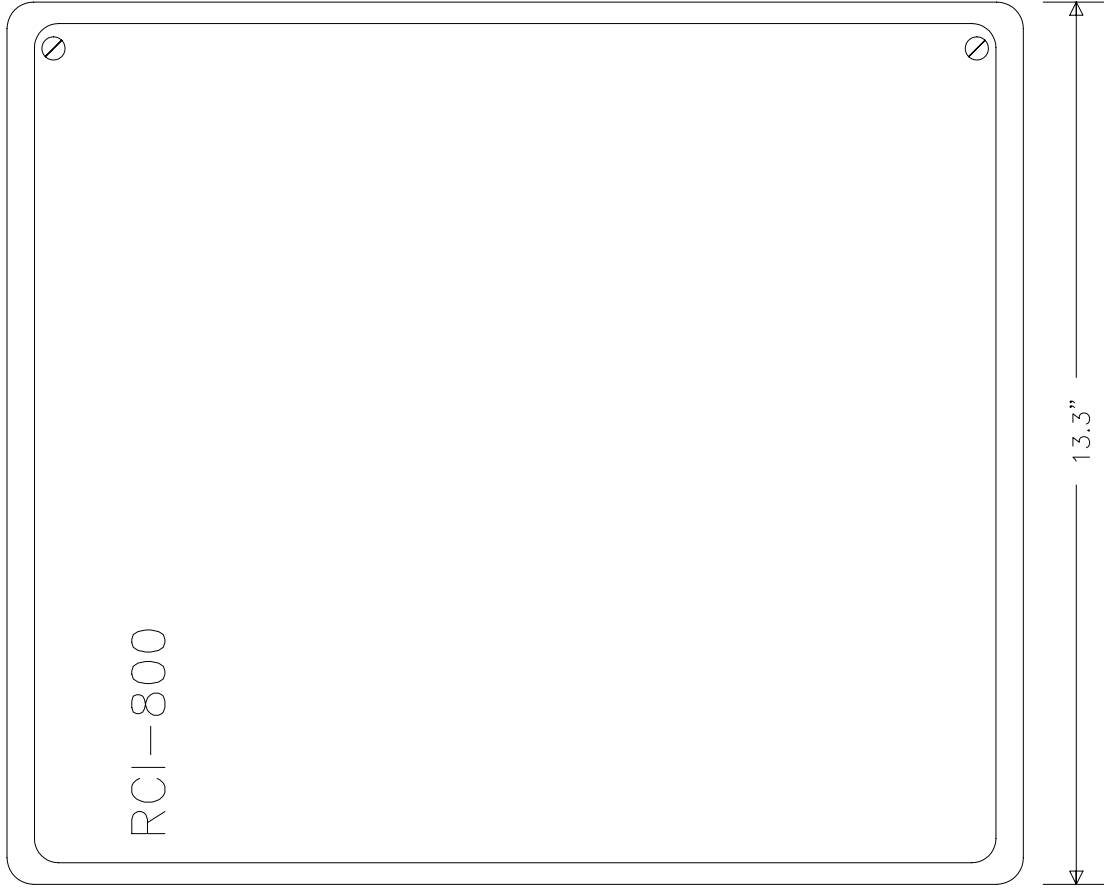

Pribusin Inc. ©	
CHKD: V.B	DATE: MAY14/10
RCI-800 ENCLOSURE DIMENSION	
DWG. NO.: 108127	REV. A

Class C Telephone Line Transmission (Several Miles)

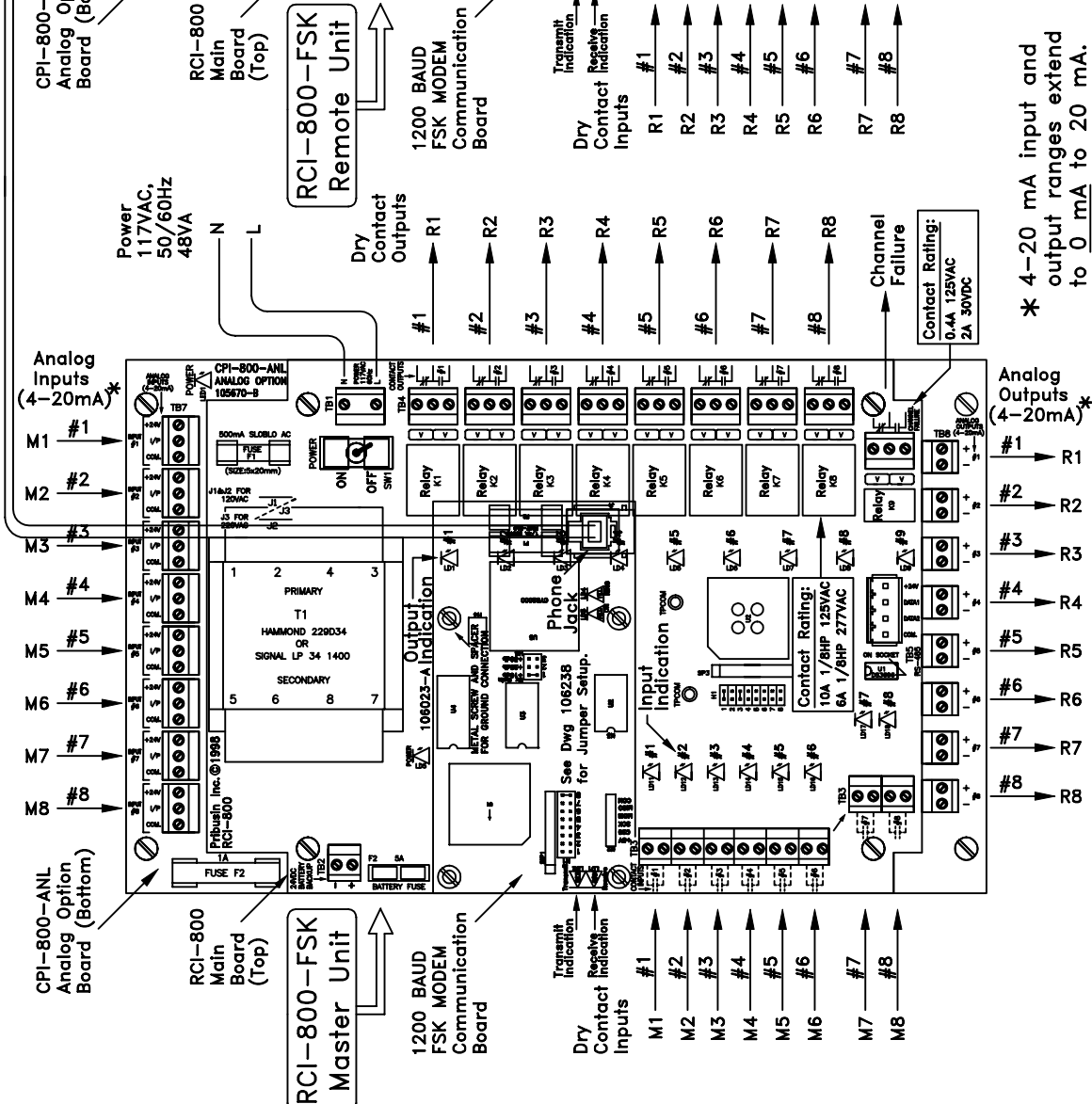
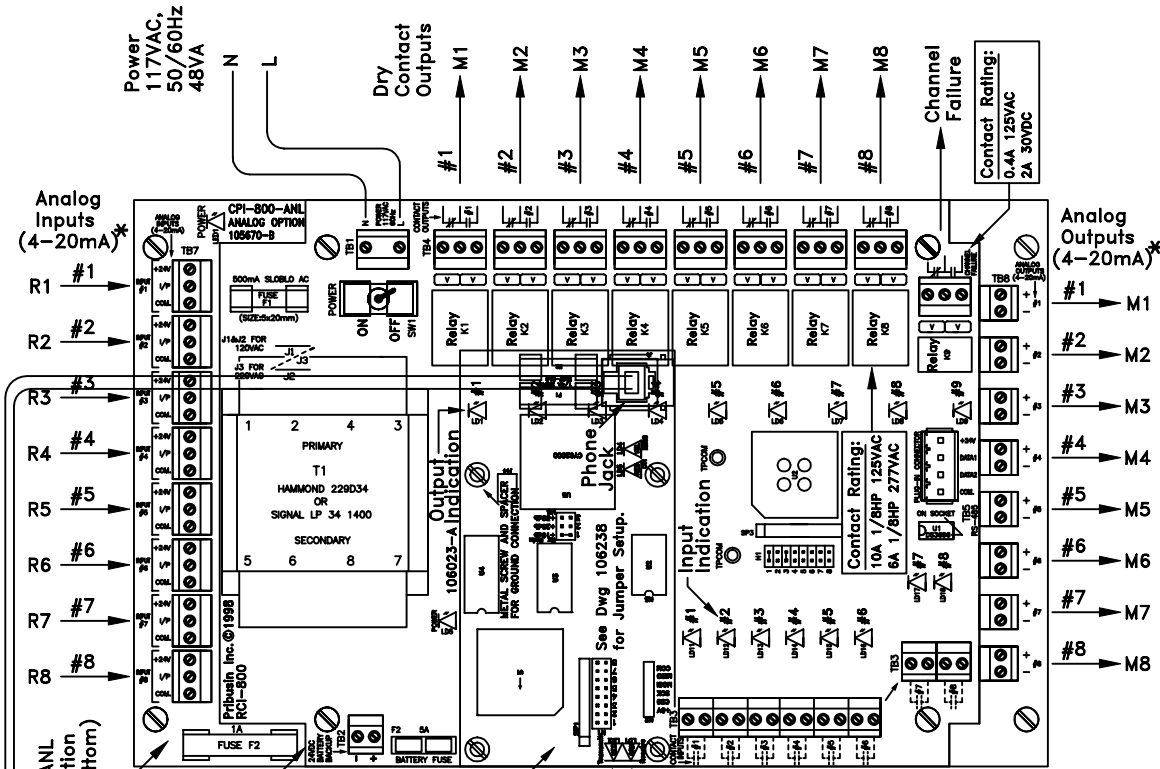

\* 4-20 mA input and output ranges extend to 0 mA to 20 mA.

Notes:

1. For Functional Description of this Communication System, See Dwg 106235 & 106238.
2. For Close View of RCI-800-FSK Unit, See dwg 106237.
3. For Details on Class C Telephone Line Transmission, See Dwg 105815.
4. For Enclosure Details, See Dwg 106239 & 106240.

**Pribusin Inc. ©**

<b>CHKD :</b>	<b>DATE :</b> Dec. 09/99	<b>DRN :</b> KS	
<b>Model: RCI-800-FSK</b>			
<b>Remote Control Signal Interface</b>			
<b>Typical Connection Diagram</b>			
<b>DWG. NO. :</b>	<b>106236</b>	<b>REV. A</b>	

Class C Telephone Line Transmission (Several Miles) →

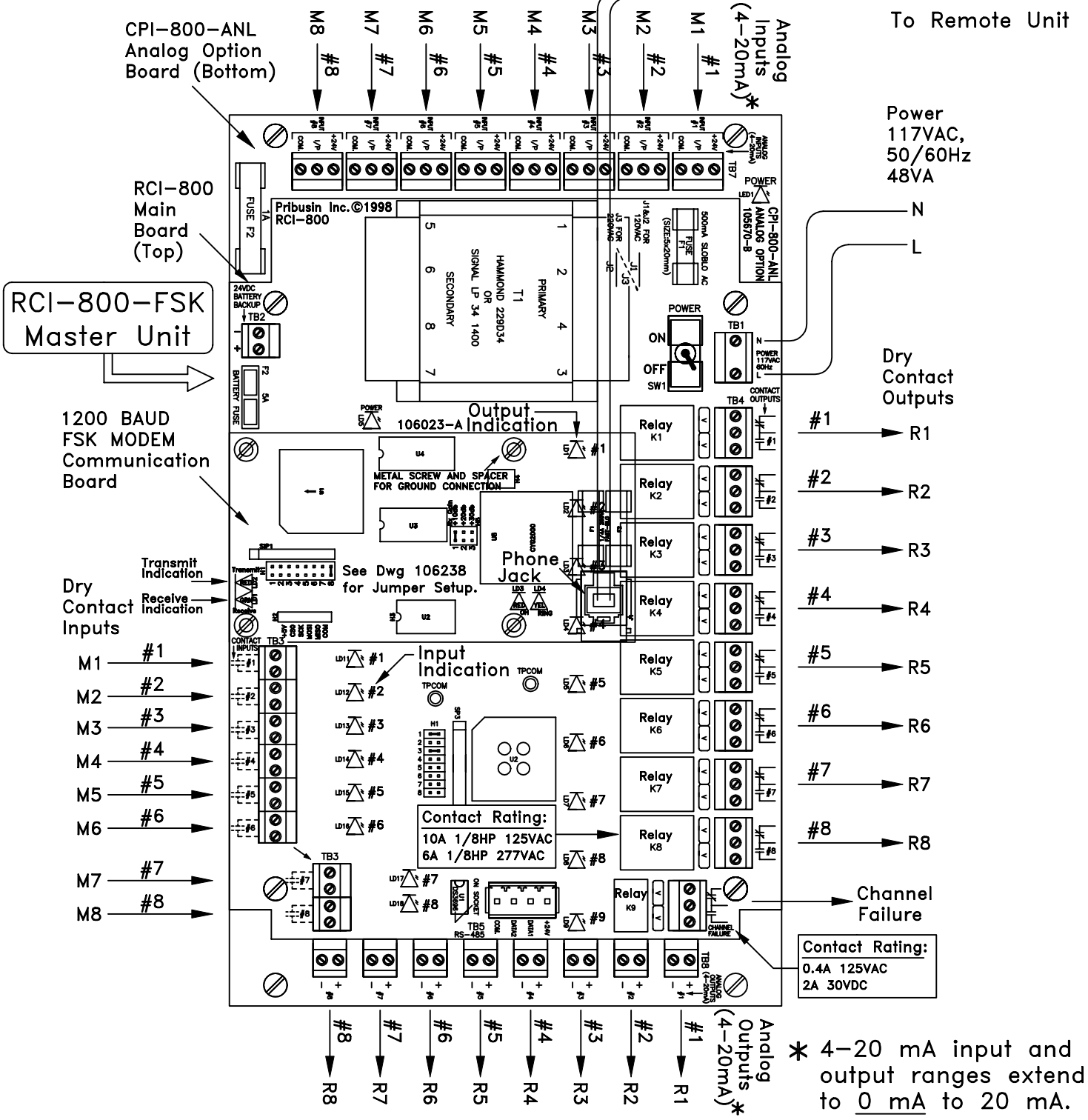

Power  
117VAC,  
50/60Hz  
48VA

Dry  
Contact  
Outputs

\* 4-20 mA input and  
output ranges extend  
to 0 mA to 20 mA.

RCI-800-FSK  
Master Unit

1200 BAUD  
FSK MODEM  
Communication  
Board

Dry  
Contact  
Inputs

- Notes:
1. For Functional Description of this Communication System, See Dwg 106235 & 106238.
  2. For Typical Connection Diagram, See Dwg 106236.
  3. For Details on Class C Telephone Line Transmission, See Dwg 105815.
  4. For Enclosure Details, See Dwg 106239 & 106240.

<b>Pribusin Inc. ©</b>		
CHKD :	DATE : Dec. 09/99	DRN: KS
Model: RCI-800-FSK Remote Control Signal Interface Close View of RCI-800-FSK Unit		
DWG. NO. :	106237	REV. A

## Class C signal and control channel transmission characteristics

Type of Service :	Signal and control circuits by voice frequency tones/voice circuit alternate use of channel
Maximum information rate :	600 bauds
Mode of operation :	2 point or multipoint Half or full duplex (2 point only full duplex)
Method of termination :	2 wire or 4 wire
Impedance—source & load :	600 ohms, balanced & resistive
Impedance of channel :	Nominal 600 ohms
Maximum signal power :	-8 dbm composite tones (0 TLP)
Maximum voice level :	-8 Vu. (0 TLP) <i>Note: 0 TLP is zero level transmission reference point, generally sending station.</i>
Loss 1000 Hz :	20 db maximum (L)
Frequency Response	
350-2750 Hz :	-3 to +6 db referred to (L)
Outside this band :	Not specified—no DC transmission
Circuit background noise :	30 db signal-to-noise ratio minimum

**Pribusin** Inc. ©

CHKD :      DATE : Apr. 17/97      DRN: KS

**Details on Class C  
Telephone Line Transmission**

DWG. NO. :      105815      REV. A

## RCI-800 Connections:

The RCI-800 is the main board of an RCI-800-XXX Telemetry system. It provides the input and output signal connections as well as the power supply for the unit. The RCI-800 consists of two circuit boards: a main controller board with eight contact inputs and eight contact outputs and below it an analog input/output board with eight analog inputs and eight analog outputs. A separate communications board is added to the RCI-800 to allow it to communicate with other units. This communications board may have its own configuration that is in a separate section of this manual. The following configuration applies only to the RCI-800 board and is common to all communications interfaces.

### AC Power & Fuse:

The RCI-800 is typically powered from 120VAC and protected by a 500mA SLOBLO fuse. It can be wired for 240VAC operation by removing (desoldering) power jumpers J1 & J2 and installing (soldering) jumper J3.

When changing the RCI-800 to 240VAC power make sure to change the fuse to half of its value, 250mA. This is important since at 240VAC the RCI-800 requires only half the current as if it were powered from 120VAC. Proper protection is only achieved by reducing the fuse value as mentioned above.

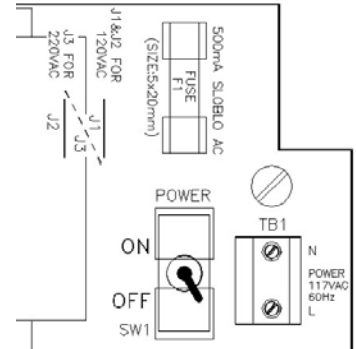

### DC Power & Battery Backup:

The RCI-800 may also be powered from a 24VDC source which could be a battery or a DC power supply. The 24VDC power input is polarity protected with a fuse to prevent damage to the RCI-800 by inadvertent reverse polarity. A DC fuse provision is also provided if this power option is utilized. Insert a 5A automotive type blade fuse into the Battery Fuse socket.

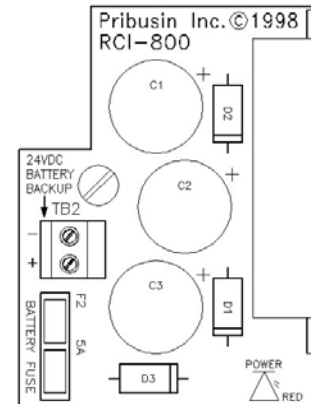

A separate 1A fuse protects the 24VDC power output to field transmitters (+24V terminal on analog inputs). This fuse is located on the analog input output board (bottom board).

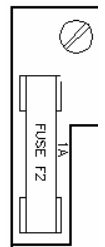

## Inputs:

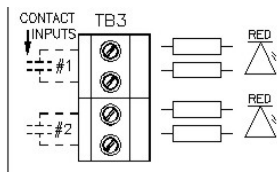

The RCI-800 has eight dry contact inputs and eight 0-20mA inputs. The dry contact inputs are excited with 24VDC and will source approximately 20mA when the contact is closed. A red LED lights up when a contact input is closed.

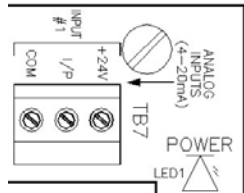

The analog inputs are configured as 0-20mA inputs and have a 250Ω input impedance. Each input terminal has three connections: +24V, I/P, COM. The +24V power output may be used to power field transmitters. Up to 125mA may be used to power a transmitter. The input signal is connected to I/P(+) and COM(-).

Analog inputs are connected to the RCI-800 in two fashions: 1) Normal (3-wire connection) or 2) two-wire connection. On a 3-wire connected input, an external power supply or the +24V power output terminal of the RCI provides power to the field transmitter. The field transmitter has a current source that provides the 4-20mA signal back to the RCI-800. If using the power supply of the RCI-800, the field transmitter may draw up to 125mA. A total of 1A is available to power up to 8 field transmitters.

On a 2-wire connected input, the field transmitter receives power from the RCI-800 and superimposes the signal onto the power return path. A maximum of 20mA will flow in such a connection. Make sure to consult the field transmitter manual to determine how to connect it to the RCI-800.

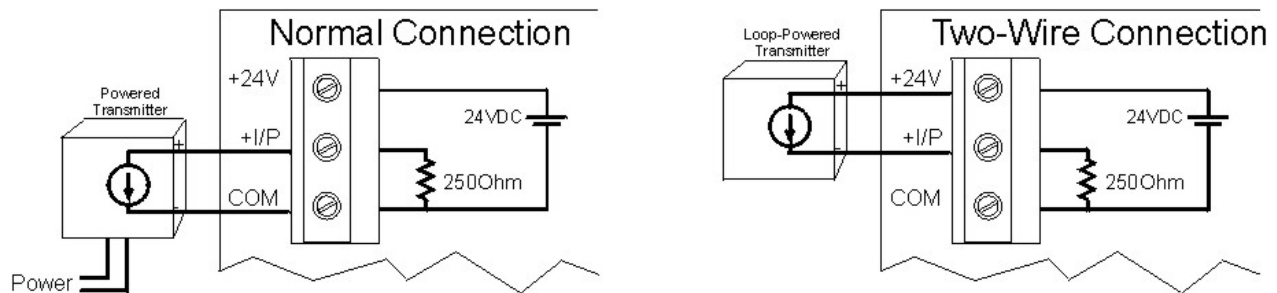

## Outputs:

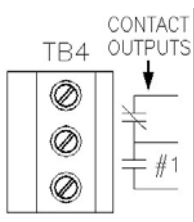

The RCI-800 has eight form 'C' relay contact outputs and eight 0-20mA analog outputs. The relay contacts are capable of switching 120VAC, 10A or 240VAC, 6A. An energy absorbing varistor is installed across each contact to limit switching transients. A ninth relay contact acts as a communications fail indicator. If no communication occurred within 60 seconds, this relay contact will energize. Upon re-established communication this relay will de-energize again.

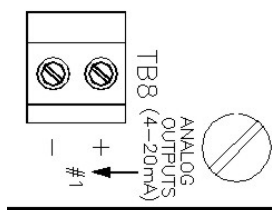

The eight analog outputs are typically configured as 0-20mA outputs and can drive into a 1000Ω load each, provided that the power supply to the unit is not below 24VDC. The outputs are not isolated from each other or from the inputs. Care must be taken when connecting the outputs to different devices so that no inadvertent ground loops are established.

## Output Calibration & Input Testing:

The outputs on the RCI-800 are factory calibrated and should not require any adjustments. To check the calibration of the outputs and relays use jumpers H1-7 & H1-8 as shown below to set them to known states. If an output should require some adjustment, the main circuit board has to be removed from the analog input/output board to gain access to the output calibration potentiometers. **With the power off**, remove the main circuit board and set it aside leaving it connected to the analog input/output board via the 4-conductor I/O cable. Turn the power on and insert jumper H1-8 on the main circuit board and turn the OUTPUT CALIB. trim pot for a particular output until that output reads 20mA. Turn the power off again before re-assembling the unit.

H1-7	H1-8	Function
OUT	OUT	Normal Operation
OUT	IN	Outputs=20mA, Relays=Energized
IN	OUT	Outputs=0mA, Relays=De-energized
IN	IN	Outputs=Inputs, Relays=Contact Inputs

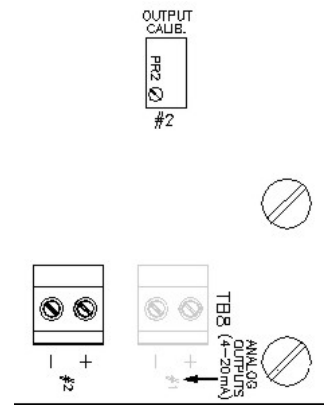

If both jumpers are IN the analog and contact inputs are passed straight through to the analog and relay outputs. This may help in troubleshooting input and output signals.

**Make sure both jumpers are removed before resuming normal operation.**

## RCI-800 Configuration:

The RCI-800 requires no configuration other than for its communication fail operation. In the event of a communications failure on the communications board, the RCI-800 can be set up to take various actions on its outputs. This may be desirable in order to place connected devices into a safe operating mode. By default factory setting, all outputs remain at their last known state if a communications failure occurs.

H1-	Function	OUT	IN
1	Relay Fail Mode	No Change	See H1-2
2	Relay Fail Status	De-Energize	Energize
3	Output Fail Mode	No Change	See H1-4 <sup>1)</sup>
4	Output Fail Status	Ramp to 0%	Ramp to 100%
5	Output 0% Value <sup>2)</sup>	0mA	4mA
6	Output Ramp Rate	10 seconds	60 seconds
7	I/O Calibration		
8	I/O Calibration		

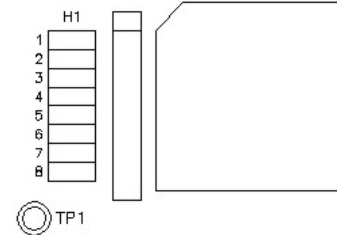

- 1) If H1-3=IN then all analog outputs will ramp to the either 0% or 100% depending on jumper H1-4. the outputs will change at a rate determined by the jumper H1-6.
- 2) The low end of the output value can be selected to be either 0mA or 4mA depending on jumper H1-5. This setting only applies to the output value during a fail condition when the outputs are selected to ramp to 0%. If jumper H1-5 is out, the outputs will ramp to 0mA, if it is in they will ramp to 4mA. The setting of this jumper does not affect the outputs during normal operation.

## FSK Communication Option:

The -FSK communications option for the RCI series utilizes Frequency Shift Keying modems on a leased telephone line to exchange the signal data between a host and its remote(s). There are two types of **Topologies** that can be configured: 1) Point-to-Point and 2) Host-to-Multipoint.

In a **Point-to-Point** topology one host communicates with one remote. The two exchange all their signals with one another. The remote is configured as remote #1 even though it is the only remote in the system.

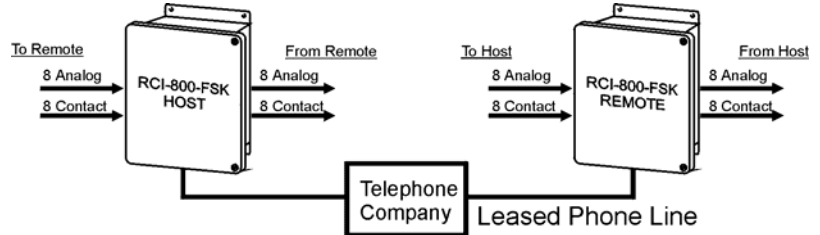

In a **Host-to-Multipoint** topology one host communicates to several remotes. Each remote is assigned an address (1,2,3, etc.) so that the host may distinguish between them. There may at most be as many remotes as there are inputs & outputs on the host.

There are two ways to physically connect a Host-to-Multipoint system:

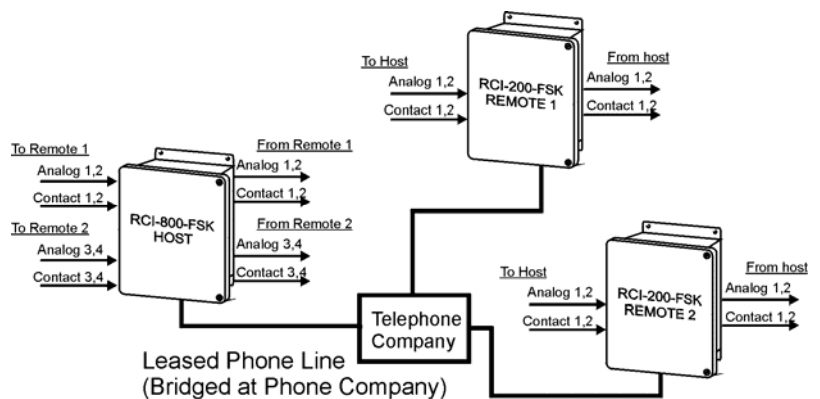

1) Bridging the remotes' leased lines at the phone company resulting in one leased line being connected at the host (**preferred method**). This eliminates any impedance mismatch issues that may arise by connecting two or more phone lines in parallel.

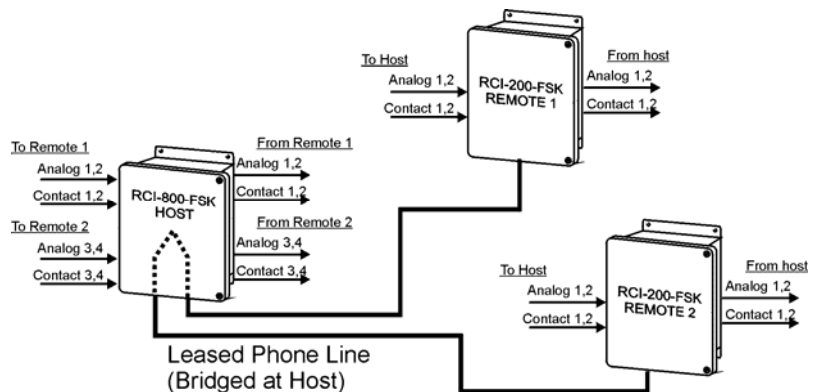

2) Bridging the remotes' leased lines at the host. This can cause problems in some cases because of impedance mismatches in the two lines. It also attenuates the FSK signal, which means that a higher amplification setting on the FSK board is necessary. If there is excess noise on the lines this would now also be amplified and may interfere with the signal.

An RCI-800 configured as a host may communicate in one of the following system setups:

- a) **1** RCI-800 remote
- b) **2** RCI-800 remotes configured as 4-channel remotes
- c) **4** RCI-200 remotes each having 2 channels
- d) **8** RCI-200 remotes configured as 1-channel remotes

Host (8-Channel)	Remote #1 (8-Channel)
DI 1-8	DO 1-8
DO 1-8	DI 1-8
AI 1-8	AO 1-8
AO 1-8	AI 1-8

Host (8-Channel)	Remote #1 (2-Channel)	Remote #2 (2-Channel)	Remote #3 (2-Channel)	Remote #4 (2-Channel)
DI 1-2	DO 1-2			
DI 3-4		DO 1-2		
DI 5-6			DO 1-2	
DI 7-8				DO 1-2
DO 1-2	DI 1-2			
DO 3-4		DI 1-2		
DO 5-6			DI 1-2	
DO 7-8				DI 1-2
AI 1-2	AO 1-2			
AI 3-4		AO 1-2		
AI 5-6			AO 1-2	
AI 7-8				AO 1-2
AO 1-2	AI 1-2			
AO 3-4		AI 1-2		
AO 5-6			AI 1-2	
AO 7-8				AI 1-2

Host (8-Channel)	Remote #1 (4-Channel)	Remote #2 (4-Channel)
DI 1-4	DO 1-4	
DI 5-6		DO 1-4
DO 1-4	DI 1-4	
DO 5-6		DI 1-4
AI 1-4	AO 1-4	
AI 5-6		AO 1-4
AO 1-4	AI 1-4	
AO 5-6		AI 1-4

The above tables show the input-output relationships for the a), b) & c) system configurations. For space reasons the table for system d) was omitted but can easily be deduced from the system c) table.

## FSK Modem Configuration:

All FSK modem configurations are done via two banks of DIPswitches. SW1-1, -2, & -3 assigns the remote address from 1 to 8 using a binary encoding scheme. SW2 assigns the Topology, Channel Numbers and Host/Remote Mode. The switches are located on the communications board just above the main circuit board. They are slide switches that slide **UP for ON** and **DOWN for OFF**.

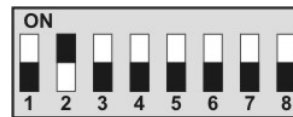

**SW1-ADDRESS**

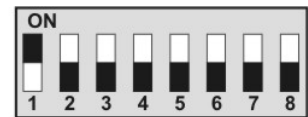

**SW2- FUNCTION**

The FSK communication board has two banks of 8-position DIPswitches: SW1 and SW2. The function of these switches is slightly different for a host unit and a remote unit.

SW1-	HOST	REMOTE
1	# of Remotes	Remote Address
2	# of Remotes	Remote Address
3	# of Remotes	Remote Address
4		
5		
6		
7		
8		

SW2-	HOST	REMOTE
1	# of Channels on each Remote	# of Channels on this Remote
2	# of Channels on each Remote	# of Channels on this Remote
3	# of Channels on Host	
4	# of Channels on Host	
5		
6		
7		
8	Host / Remote Select	Host / Remote Select

## Host Configuration:

To make an RCI-800 operate as a host unit, make sure that SW2-8 is flipped down.



**SW1-ADDRESS**



**SW2- FUNCTION**

Next, set the **number of remotes** that the host is to communicate with using SW1-1, -2, -3. These switches are binary encoded as shown in the chart to the right.

SW1-1	SW1-2	SW1-3	# of Remotes
OFF	OFF	OFF	1
ON	OFF	OFF	2
OFF	ON	OFF	3
ON	ON	OFF	4
OFF	OFF	ON	5
ON	OFF	ON	6
OFF	ON	ON	7
ON	ON	ON	8

1 Remote		5 Remote	
2 Remote		6 Remote	
3 Remote		7 Remote	
4 Remote		8 Remote	









Next, set the **number of channels of each remote** using SW2-1, -2. One channel is considered 1 analog input/output plus 1 contact input/output. Hence an RCI-800 can have UP TO 8 channels. Remotes can only come in 1, 2, 4 or 8 channel configurations

SW2-1	SW2-2	Channels on Remotes
OFF	OFF	1
ON	OFF	2
OFF	ON	4
ON	ON	8

1 Channel	
2 Channels	
4 Channels	
8 Channels	

Next, set the **number of channels of the host** using SW2-3, -4. An RCI-800 can have 8 channels. This is the number of channels that will be exchanged between the host and each remote. To match the total number of channels on all remotes, select the number of channels for the host.

SW2-3	SW2-4	Channels on Host
OFF	OFF	1
ON	OFF	2
OFF	ON	4
ON	ON	8

1 Channel	 SW1-ADDRESS	 SW2-FUNCTION
2 Channels	 SW1-ADDRESS	 SW2-FUNCTION
4 Channels	 SW1-ADDRESS	 SW2-FUNCTION
8 Channels	 SW1-ADDRESS	 SW2-FUNCTION

















**Remote Configuration:**

To make an RCI-800 operate as a REMOTE unit, make sure that SW2-8 is flipped up.











Next, set the **remote address** using SW1-1, -2, & -3. This switch is binary encoded and you will have to convert the remote address to binary first.

SW1-1	SW1-2	SW1-3	Remote Address
OFF	OFF	OFF	1
ON	OFF	OFF	2
OFF	ON	OFF	3
ON	ON	OFF	4
OFF	OFF	ON	5
ON	OFF	ON	6
OFF	ON	ON	7
ON	ON	ON	8

1 Remote	 	5 Remote	 
2 Remote	 	6 Remote	 
3 Remote	 	7 Remote	 
4 Remote	 	8 Remote	 

Next, set the **number of channels on this remote** using SW2-1, -2. One channel is considered 1 analog input/output plus 1 contact input/output. Hence an RCI-800 can have up to 8 channels.

SW2-1	SW2-2	Channels on Remote
OFF	OFF	1
ON	OFF	2
OFF	ON	4
ON	ON	8

1 Channel	 
2 Channels	 
4 Channels	 
8 Channels	 

### Receiver Gain Adjustment:

The FSK modem has a receive amplifier that can be used in various stages of amplification to enhance communication. If the phone line quality is poor or if the distance between units is great and presents a large signal loss, increasing the receiver gain can be used to amplify the incoming signal to restore reliable communication. Three gain settings are available: +10dB, +20dB and +30dB. These are selected via switch SW3. If all three switches are off, there is no amplification.

Use the lowest amplification setting that yields good results since too high of an amplification setting can distort the signal yielding unreliable communication also. To judge the state of your communication, use the RED and GREEN Transmit and Receive LEDs.

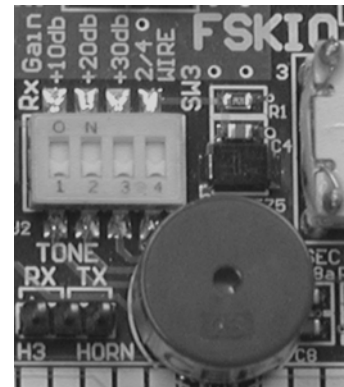

### Transmit, Receive & Link Indicators:

The RCI FSK modem board has four indicators (LEDs) near the left edge that indicate *Power* “+5V” (RED), *Link* (YELLOW), *Transmit* “TX” (RED) and *Receive* “RX” (GREEN). On a host unit, the RED Transmit LED will light first for a fraction of a second. This is an interrogation message sent to one of the remotes. If the remote received the message entirely and correctly, it will reply with a return message, which causes the host’s GREEN Receive LED to light for a fraction of a second. This is followed by the host then sending out the next message and so on.

In other words, every Transmit LED flash should be followed by a Receive LED flash. If a Transmit LED flash is NOT followed by a Receive LED flash this means that one of the remotes did not receive its interrogation message properly or is currently not powered or there is a problem with the leased telephone line. By changing the receiver gain setting try to achieve a continuous Transmit/Receive LED flash pattern.

Occasional transmission misses are of no real concern since the units wait for 1 minute during a continuous communication loss before signaling a loss of communication. During this 1-minute delay all outputs are held at their last known value.

On a remote unit, the order of the LED flashes is reversed since the remote waits for an interrogation message from the host before it replies. The Receive LED will flash first followed by a flash of the Transmit LED.

A complete data exchange requires 4 transmissions between the host and a remote. This becomes important when considering a Host-to-Multipoint system. On the host the LED flash sequence remains unchanged. On the remote units, however, the Receive LED will flash every time any message is sent on the phone line. This includes messages not intended for a given remote. For example, if the host is currently communicating with remote #1, the Receive LED on remote #2 will flash for every interrogation and reply message that are exchanged between the host and remote #1. Only when the host begins to communicate with remote #2 does the normal Receive/Transmit flash sequence occur.

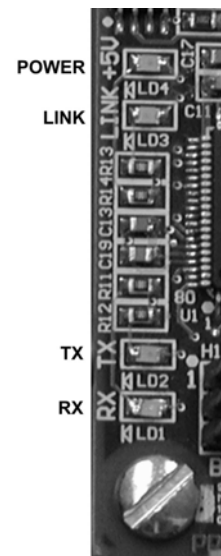

## Leased Line Connection & Specifications:

The RCI-XXX-FSK uses a leased line to communicate. A leased line is a regular telephone line without the dial tone. It is essentially always ON. If you were to connect a telephone at either end and both people were to pick up the receiver they could just start talking.

**The leased line must be specially installed by the telephone company and they may have various services available. The RCI-XXX-FSK does not require a special type of service (such as data, full-duplex, etc.). All that is required is a 2-wire or 4-wire, un-powered, voice-grade line without dial tone.**

### 2-Wire vs. 4-Wire Phone Line Connection:

The RCI-XXX-FSK can operate on either a 2-wire or a 4-wire leased phone line. SW3-4 selects the type of leased phone line that is connected to the RCI-XXX-FSK. All units of one system must use the same type of connection (either 2-wire or 4-wire). Four fuses are provided for protection of the FSK modem. They are a 1/4A fast-blo 5x20mm type.

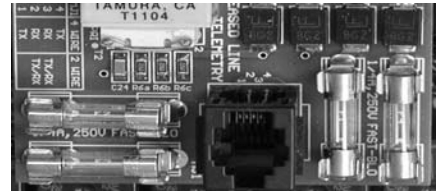

**We strongly suggest installing additional surge and lightning protection at the point where the leased line enters the building.** The protection on the FSK modem board is not sufficient to protect against lightning strikes or large power surges.

On a **2-wire leased phone line** (SW3-4 ON), data is transmitted and received over a single pair of wires using the inner two pins of the RJ-11 phone jack (pins 2 & 3). On a standard phone cable these wires are red and green and they are connected the same way on all units. Polarity does not matter and red and green wires may be interchanged.

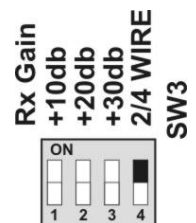
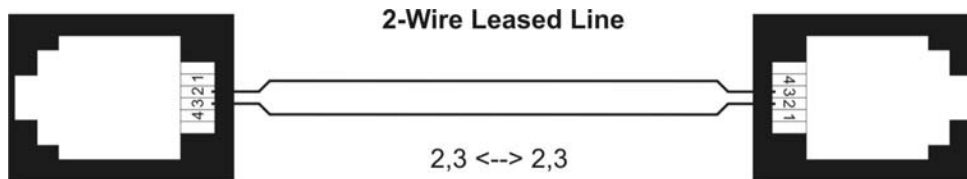

On a **4-wire leased phone line** data is transmitted on the outer two pins of the RJ-11 phone jack (pins 1 & 4) and received on the inner two pins of the RJ-11 phone jack (pins 2 & 3). On a standard phone cable the outer two wires are black and yellow while the inner two wires are red and green. It is important that the transmit pair (pins 1 & 4) from one unit is connected to the receive pair (pins 2 & 3) on the other units and vice versa.

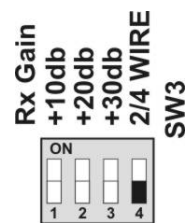
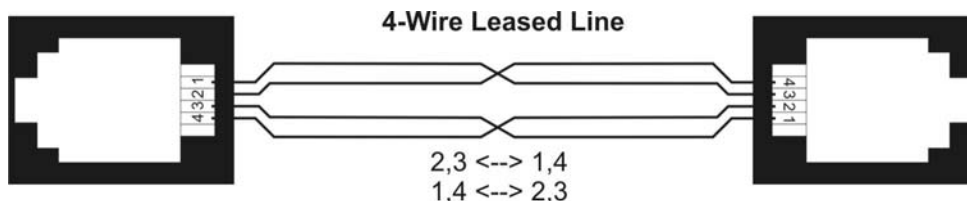

## Point-to-Point Communication

Communication between one host and one remote is called point-to-point.

### Example 1: An RCI-100 Host communicating with an RCI-100 Remote



SW1-ADDRESS



SW2- FUNCTION

#### **RCI-100 (Host)**

Host Channels: 1  
Number of Remotes: 1  
Channels on Remotes: 1



SW1-ADDRESS



SW2- FUNCTION

#### **RCI-100 (Remote)**

Remote Channels: 1  
Address: 1

### Example 2: An RCI-200 Host communicating with an RCI-200 Remote



SW1-ADDRESS



SW2- FUNCTION

#### **RCI-200 (Host)**

Host Channels: 2  
Number of Remotes: 1  
Channels on Remotes: 2



SW1-ADDRESS



SW2- FUNCTION

#### **RCI-200 (Remote)**

Remote Channels: 2  
Address: 1

### Example 3: An RCI-400 Host communicating with an RCI-400 Remote



SW1-ADDRESS



SW2- FUNCTION

#### **RCI-400 (Host)**

Host Channels: 4  
Number of Remotes: 1  
Channels on Remotes: 4



SW1-ADDRESS



SW2- FUNCTION

#### **RCI-400 (Remote)**

Remote Channels: 4  
Address: 1

### Example 4: An RCI-800 Host communicating with an RCI-800 Remote



SW1-ADDRESS



SW2- FUNCTION

#### **RCI-800 (Host)**

Host Channels: 8  
Number of Remotes: 1  
Channels on Remotes: 8



SW1-ADDRESS



SW2- FUNCTION

#### **RCI-800 (Remote)**

Remote Channels: 8  
Address: 1

## Point-to-Multipoint Communication

Communication between a host and more than one remote is called point-to-multipoint.

### Example 1: An RCI-200 Host communicating with (2) RCI-100 Remotes

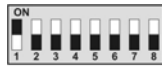

SW1-ADDRESS



SW2- FUNCTION



SW1-ADDRESS



SW2- FUNCTION



SW1-ADDRESS



SW2- FUNCTION

#### **RCI-200 (Host)**

Host Channels: 2  
Number of Remotes: 2  
Channels on Remotes: 1

#### **RCI-100 (Remote 1)**

Remote Channels: 1  
Address: 1

#### **RCI-100 (Remote 2)**

Remote Channels: 1  
Address: 2

### Example 2: An RCI-400 Host communicating with (2) RCI-200 Remotes



SW1-ADDRESS



SW2- FUNCTION



SW1-ADDRESS



SW2- FUNCTION



SW1-ADDRESS



SW2- FUNCTION

#### **RCI-400 (Host)**

Host Channels: 4  
Number of Remotes: 2  
Channels on Remotes: 2

#### **RCI-200 (Remote 1)**

Remote Channels: 2  
Address: 1

#### **RCI-200 (Remote 2)**

Remote Channels: 2  
Address: 2

### Example 3: An RCI-800 Host communicating with (2) RCI-400 Remotes



SW1-ADDRESS



SW2- FUNCTION



SW1-ADDRESS



SW2- FUNCTION



SW1-ADDRESS



SW2- FUNCTION

#### **RCI-800 (Host)**

Host Channels: 8  
Number of Remotes: 2  
Channels on Remotes: 4

#### **RCI-400 (Remote 1)**

Remote Channels: 4  
Address: 1

#### **RCI-400 (Remote 2)**

Remote Channels: 4  
Address: 2

Example 4: An RCI-800 Host communicating with (3) RCI-200 Remotes

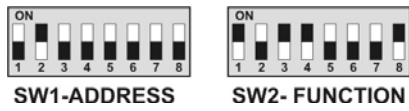

**RCI-800 (Host)**

Host Channels: **8**  
Number of Remotes: **3**  
Channels on Remotes: **2**



**RCI-200 (Remote 1)**

Remote Channels: **2**  
Address: **1**

**RCI-200 (Remote 2)**

Remote Channels: **2**  
Address: **2**

**RCI-200 (Remote 3)**

Remote Channels: **2**  
Address: **3**