



*Manufacturers of Process
Controls and Instrumentation*

Instruction Manual

Model: *TWI-TXX*

Function: *Two Wire Thermocouple Transmitter*

Input Range:

- X= : 0-300 Deg. F. Type _____
- X= : 0-400 Deg. F. Type _____
- X= : 0-500 Deg. F. Type _____
- X= : 0-750 Deg. F. Type _____
- X= : 0-1000 Deg. F. Type _____
- X= : 0-1500 Deg. F. Type _____

- X= : -350 to 1100 Deg. F. Type _____

Output: 4-20mA

Power:

Serial #: _____ (If special or required)

For Technical Assistance And Questions Call
USA: (231) 788-2900 CANADA: (905) 660-5336

Restocking Policy

All product returned to Pribusin Inc. in prime condition (not damaged, scratched or defaced in any way) within seven (7) months from the original date of shipment is subject to a 50% restocking charge. All product must be accompanied by a Return Authorization number (RA number) which must be obtained from Pribusin Inc. prior to returning any product.

After seven (7) months from the original date of shipment, products cannot be returned for restocking.

Custom designed products, modified products or all non-standard products may not be returned for restocking.

Warranty Policy

Pribusin Inc. warrants equipment of its own manufacture to be free from defects in material and workmanship, under normal conditions of use and service, and will replace any component found to be defective, on its return to Pribusin Inc., transportation charges prepaid, within one year of its original purchase. Pribusin Inc. will extend the same warranty protection on equipment, peripherals and accessories which is extended to Pribusin Inc. by the original manufacturer. Pribusin Inc. also assumes noliability, expressed or implied, beyond its obligation to prelace any component involved. Such warranty is in lieu of all other warranties, expressed or implied.



Standard features:

- High Input to Output Isolation (800 VAC Test)
- Small Size - Fits in Standard Explosion Proof Housing
- Industry Standard 4-20 mA Output
- Standard Ranges for Type J,K,E,T,S,R
- Special Ranges and other Types available
- Cold Junction Compensated
- Standard Upscale Protection on all Units
- Wide Operating Range (12 to 60 VDC)
- High Noise Rejection
- CSA and NRTL Approved (LR 51078)

Function:

The TWI-TXX is an isolated two wire thermocouple transmitter that comes in a small, explosion proof housing compatible package. It has easily accessible screw terminals and is built into a rugged housing.. The many different Thermocouple types and ranges allow it to be used in a great variety of temperature measurement applications.

Upscale protection is standard on all units unless downscale protection is specified.

Temperature Conversion Equations:

$$^{\circ}\text{C} = \frac{5}{9} (^{\circ}\text{F} - 32)$$

$$^{\circ}\text{F} = \frac{9}{5} ^{\circ}\text{C} + 32$$

$$\text{Kelvin} = ^{\circ}\text{C} + 273.15$$

$$\text{Rankin} = ^{\circ}\text{F} + 459.67$$

Specifications:

- Isolation: 800 VAC (Test)
- Operating Power: 12 to 60 VDC
- Accuracy/Linearity: +/-0.2% max., +/- 0.1% typ.
(Linear with Temperature for most Ranges)
- Response Time: 100 msec to 63% of final value
400 msec to 99% of final value
- T/C Compensation: Cold Junction Compensation
- Temperature Effects: +/- 0.025% per Deg.C.
- Span Drift: +/- 0.025% per Deg.C.
- Zero Drift: 1 uV per mV offset per Deg.C. OR
1 uV per Deg.C., whichever is greater
- Drift at 25 Deg. C.: 24 Hours: +/- 0.1%
30 Days: +/-0.2%
- Operating Temperature:-20 Deg. C. to + 50 Deg. C.
- Input Impedance: 1 Meg Ohm min.

TWI-TXX

Dimensions:

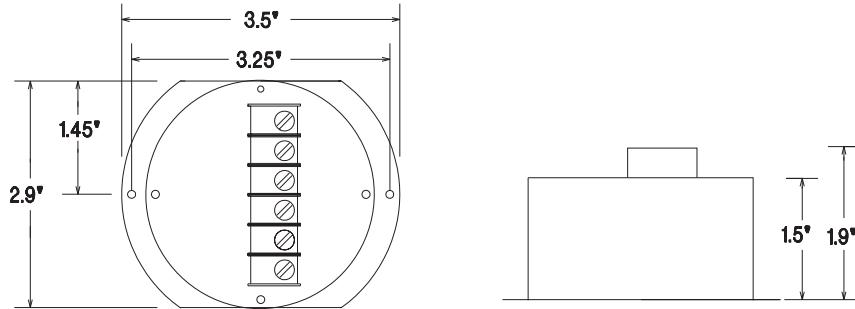

Loop Characteristics:

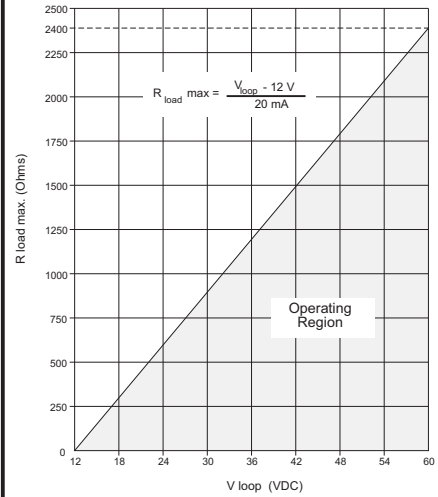

Connection:

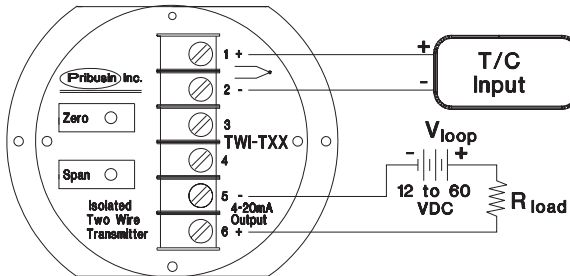

Model Designation: TWI-TXX

Example: An isolated thermocouple transmitter for a type 'K' thermocouple for 0-500F is designated by: TWI-TK2

| Range | J | K | E | T | R | S |
|----------------------------|-----|-----|-----|-----|-----|-----|
| 0 to 300F -18 to 150C | TJ1 | | TE1 | TT1 | | |
| 0 to 400F -18 to 204C | TJ2 | TK1 | TE2 | TT2 | | |
| 0 to 500F -18 to 260C | TJ3 | TK2 | TE3 | TT3 | | |
| 0 to 750F -18 to 400C | TJ4 | TK3 | TE4 | | TR1 | TS1 |
| 0 to 1000F -18 to 538C | TJ5 | TK4 | | | TR2 | TS2 |
| 0 to 1500F -18 to 816C | | TK5 | | | TR3 | TS3 |
| 0 to 2000F -18 to 1093C | | TK6 | | | TR4 | TS4 |
| 0 to 3200F -18 to 1760C | | | | | TR5 | TS5 |
| -350 to 1100F | TJ6 | TK7 | TE5 | | | |

Note: * not linearized with temperature - linear with material only

Manufactured By:

Pribusin Inc.

www.pribusin.com
info@pribusin.com

USA:

Pribusin Inc.
743 Marquette Ave.
Muskegon, MI 49442
Ph: (231) 788-2900
Fx: (231) 788-2929



CANADA:

Pribusin Inc.
101 Freshway Dr. Unit 57
Concord, Ontario, L4K 1R9
Ph: (905) 660-5336
Fx: (905) 660-4068

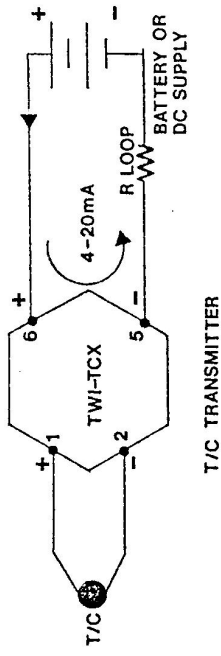
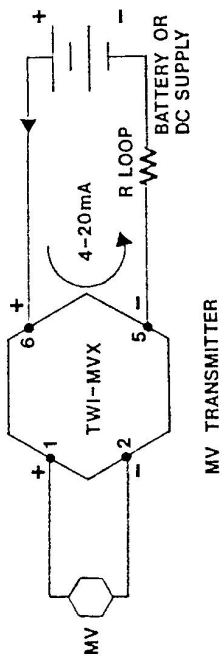
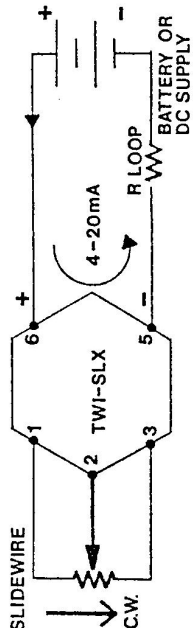
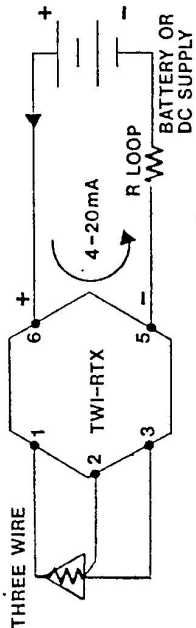
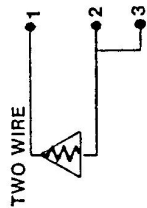

Pribusin Inc.

| | | |
|--|-------------------|---------------------|
| SCALE: | APPROVED BY: V.B. | DRAWN BY: GEO. OSI. |
| DATE: Jan. 20/88 | REVISED | |
| Connection Diagram - TWO WIRE TRANSMITTERS | | |
| DWG. NO. 102273 | DRAWING NUMBER | REV. A |

Model :TWI-TXX or TWI-TXX-TB

Calibration Procedure :

1. Set up the thermocouple input circuit as shown in Dwg. 100813 using the type of thermocouple wire as the instrument input range specifies.

Note: 1. If you are using a Thermocouple Calibrator for calibration, then you do NOT need the Ice Bath setup. You can directly hook the output of the thermocouple calibrator to the instrument under test.

2. For the Ice Bath use ice made from distilled water and distilled water. Also shake the mixture of ice and water when reading the output to keep the mixture at 0°C.

2. Apply an input signal (thermocouple mV) equal to 100 % of the input range.

3. Adjust the Span potentiometer for an output of 20.00 mA.

Note: If the output will not go down to 20 mA or will not go up to 20 mA, then the Zero potentiometer should be adjusted to get a 20 mA output.

4. Apply an input signal (thermocouple mV) equal to 0 % of the input range.

5. Adjust the Zero potentiometer for an output of 4.00 mA.

6. Repeat steps 2 to 6 until no further adjustments are required.

7. Apply an input signal (thermocouple mV) equal to 50 % of the input range, and check that the output is 12.00 mA +/- the linearity specifications.

8. Calibration is complete.

| | | |
|---|-------------------|---------|
| Pribusin Inc. © | | |
| CHKD : | DATE : NOV. 02/94 | DRN: KS |
| Model: TWI-TXX or TWI-TXX-TB Two Wire Isolated Thermocouple Transmitter Calibration Procedure | | |
| DWG. NO. : | 101391 | REV. C |

Thermocouple Input Instruments

Calibration Procedure :

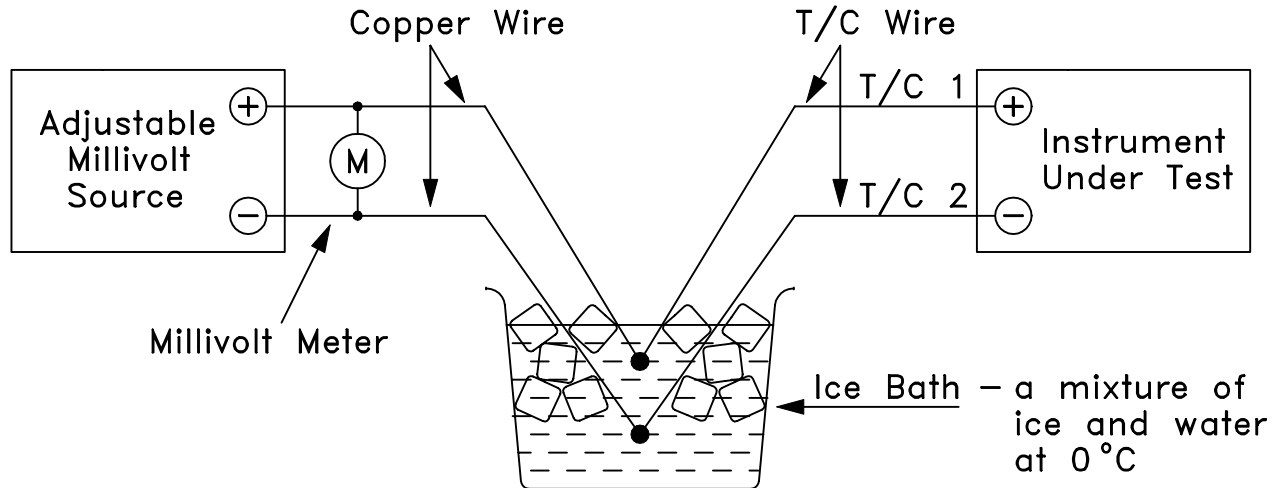

1. For calibration of thermocouple inputs, a circuit as shown above must be set up.

Note: 1. If you are using a Thermocouple Calibrator for calibration, then you do NOT need the Ice Bath setup. You can directly hook the output of the Thermocouple Calibrator to the instrument under test.

2. For the Ice Bath use ice made from distilled water and distilled water. Also shake the mixture of ice and water when reading the output to keep the mixture at 0°C.
3. The millivolt source is the temperature EMF for the required type of thermocouple reference junction at 0°C (or 32°F).
4. T/C 1 and T/C 2 are the thermocouple wire for the required type of thermocouple connected to the instrument under test in the proper polarity.

2. Connect the circuit as shown above.

3. Apply a millivolt signal as per the thermocouple tables (reference junction at 0°C) for the temperature input required, and calibrate the instrument as required.

Pribusin Inc. ©

CHKD : DATE : NOV. 02/94 DRN: KS

**Thermocouple Input Instruments
Calibration Procedure**

DWG. NO. : 100813 REV. B