

### Standard features:

- High Input-Output-Power Isolation (1500VAC Test)
- Small Size - Fits on Terminal Block Rail
- 1 Form "C" Contact Output with ON delay or ON and OFF delay
- Individual Setpoint, Deadband, Delay Adjustment
- Easy Field Calibration (Typ. calibration time < 2 min. using handheld meter only)
- Microprocessor Controlled for High Accuracy
- Two Wire Supply Option for Two Wire Transmitters
- Power: 24 VDC, 60 mA
- High Noise Rejection
- CSA and NRTL Approved (LR 51078)

### Function:

The TUA-XS Alarm Trip is a microprocessor based instrument. It can operate as a high trip or as a low trip (selectable by push-on pins inside the instrument). The relay can be configured as a normally-energized or normally de-energized. A built in two wire supply can be used to connect two wire sensors to the TUA-XS. The output is a SPDT (form "C") contact rated at 10 Amps, 1/8 Hp at 125 VAC. The deadband can be adjusted from 0-100%. The delay is adjustable from 0-1 minute and can be configured as ON delay only or as ON and OFF delay.

### Calibration:

The TPz (Test Points) are used to calibrate the setpoint, deadband, and delay functions of the TUA-XS. A voltage of 0-5 VDC on TPz represents a setting of 0-100% of the parameter z. Any parameter can be changed while the TUA-XS is in operation thus making it easy to perform field adjustments.

### Input Selection:

- X=1: 1 to 5 mA (Zin=1K Ohm)
- X=2: 4 to 20 mA (Zin=250 Ohm)
- X=3: 0 to 1 mA (Zin=5K Ohm)
- X=4: 10 to 50 mA (Zin=100 Ohm)
- X=5: 1 to 5 VDC (Zin=1Meg Ohm)
- X=6: 0 to 10 VDC (Zin=1Meg Ohm)
- X=7: Special Input

# TUA-XS

## Dimensions:

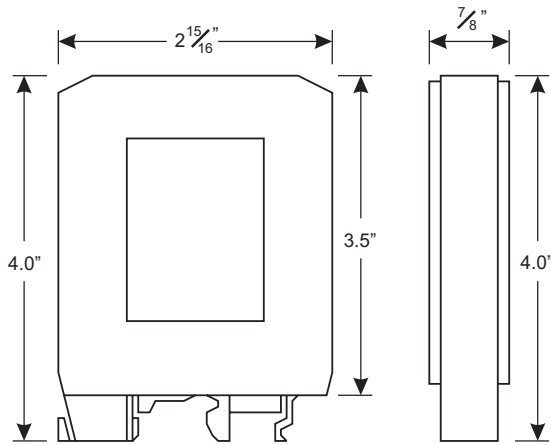

## Connection:

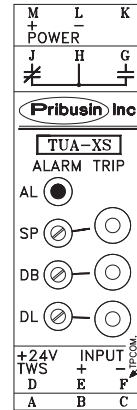

Calibration is made easy by multi-turn potentiometers with test points for meter connection

## Connection:

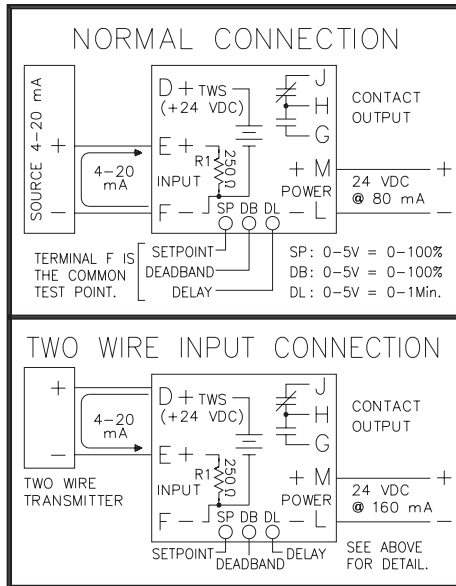

## Configuration:

	Out	In
H1	High Trip	Low Trip
H2	Energized	De-Eng.
H3	4-20mA I/P	0-20mA I/P
H4	ON Delay Only	OFF and ON Delay

The above table shows H3 for a 4-20 mA or 0-20 mA device. The same offset/zero-based input configuration holds true for all other input types.

## Specifications:

Accuracy/Linearity: +/-0.3% max., +/-0.1% typ.  
 Response Time: approx. 100msec  
 Operating Temperature: -40 Deg.C to +50 Deg.C  
 Contact Rating: 10A 1/8 Hp @ 125 VAC  
 6A 1/8 Hp @ 277 VAC

Manufactured By:



www.pribusin.com  
 info@pribusin.com

**USA:**  
 Pribusin Inc.  
 4319 E. Apple Ave.  
 Muskegon, MI 49442  
 Ph: (231) 788-2900  
 Fx: (231) 788-2929



**CANADA:**  
 Pribusin Inc.  
 101 Freshway Dr. Unit 57  
 Concord, Ontario, L4K 1R9  
 Ph: (905) 660-5336  
 Fx: (905) 660-4068