

Standard features:

- Small Size - Fits on Terminal Block Rail
- Industry Standard 4-20 mA Output
- Standard Ranges for Type J,K,E,T,S,R
- Special Ranges and other Types available
- Cold Junction Compensated
- Standard Upscale Protection on all Units
- Wide Operating Range (8 to 60 VDC)
- High Noise Rejection
- CSA and NRTL Approved (LR 51078)

Function:

The TWN-TXX-TB comes in a small, easy to install package. It has a universal DIN mount which makes it ideal for installation into crowded control panels. The many different Thermocouple types and ranges allow it to be used in a great variety of temperature measurement applications.

Upscale protection is standard on all units unless downscale protection is specified.

Temperature Conversion Equations:

$$^{\circ}\text{C} = \frac{5}{9} (^{\circ}\text{F} - 32) \quad ^{\circ}\text{F} = \frac{9}{5} ^{\circ}\text{C} + 32$$

$$\text{Kelvin} = ^{\circ}\text{C} + 273.15 \quad \text{Rankin} = ^{\circ}\text{F} + 459.67$$

Specifications:

- Operating Power: 8 to 60 VDC
- Accuracy/Linearity: +/- 0.2% max., +/- 0.1% typ.
(Linear with Temperature for most Ranges)
- Response Time: 100 msec to 63% of final value
500 msec to 99% of final value
- T/C Compensation: Cold Junction Compensation
- Temperature Effects: +/- 0.025% per Deg.C.
- Span Drift: +/- 0.025% per Deg.C.
- Zero Drift: 1 uV per mV offset per Deg.C. OR
1 uV per Deg.C., whichever is greater
- Drift at 25 Deg. C.: 24 Hours: +/- 0.1%
30 Days: +/- 0.2%
- Operating Temperature: -20 Deg. C. to + 50 Deg. C.
- Input Impedance: 1 Meg Ohm min.

TWN-TXX-TB

Dimensions:

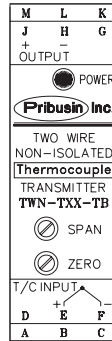
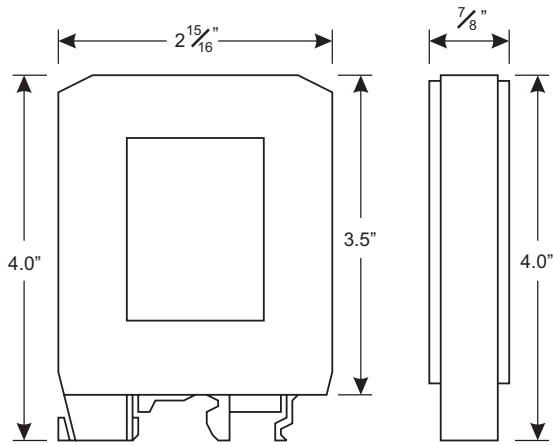

Loop Characteristics:

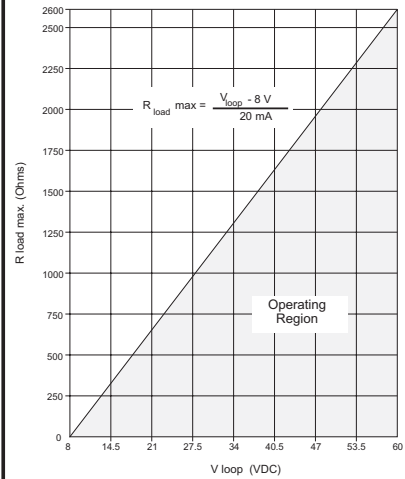

Connection:

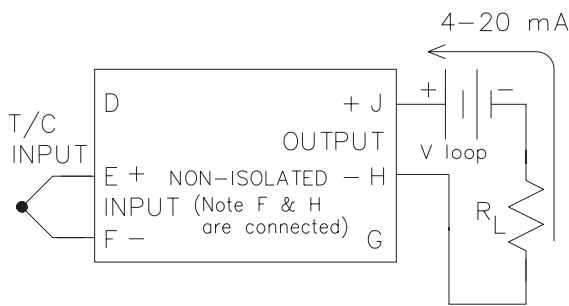

Model Designation: TWN-TXX-TB

Example: A non-isolated thermocouple transmitter for a type 'K' thermocouple for 0-500F is designated by: TWN-TK2-TB

Range	J	K	E	T	R	S
0 to 300F -18 to 150C	TJ1		TE1	TT1		
0 to 400F -18 to 204C	TJ2	TK1	TE2	TT2		
0 to 500F -18 to 260C	TJ3	TK2	TE3	TT3		
0 to 750F -18 to 400C	TJ4	TK3	TE4		TR1	TS1
0 to 1000F -18 to 538C	TJ5	TK4			TR2	TS2
0 to 1500F -18 to 816C		TK5			TR3	TS3
0 to 2000F -18 to 1093C		TK6			TR4	TS4
0 to 3200F -18 to 1760C					TR5	TS5
-350 to 1100F -200 to 600C	TJ6	TK7	TE5			

Note: * not linearized with temperature - linear with material only

Manufactured By:

Pribusin Inc.

www.pribusin.com
info@pribusin.com

USA:

Pribusin Inc.
4319 E. Apple Ave.
Muskegon, MI 49442
Ph: (231) 788-2900
Fx: (231) 788-2929



CANADA:

Pribusin Inc.
101 Freshway Dr. Unit 57
Concord, Ontario, L4K 1R9
Ph: (905) 660-5336
Fx: (905) 660-4068